

# Dual Roller Motorized FlexShade® (Standard Hardware)



## INSTRUCTIONS INSTALLATION & OPERATION

### Overview - Components

#### FLEXSHADE DFMO

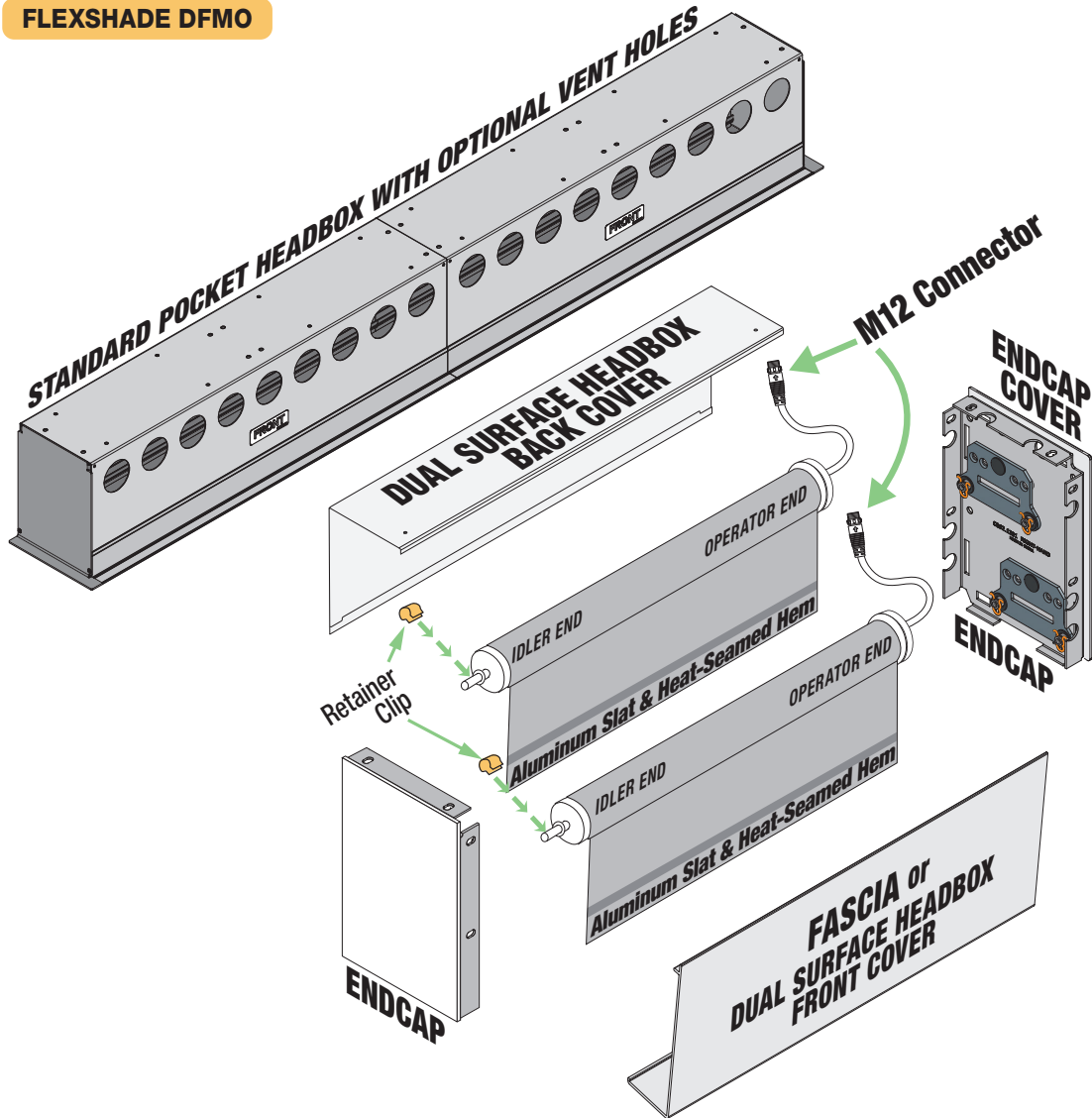

**PERSONNEL REQUIRED**

**TOOLS REQUIRED**

**⚠ CAUTION ⚠**  
Read and understand all warnings (Page 2 of this document) before beginning installation.

Contents	
Overview - Components.....	1
PLEASE READ - Important Safety and Installation Information .....	2
PLEASE READ - Field Adjustments, Cleaning and Maintenance.....	2
Section 1 - Mounting Endcaps.....	3
Section 2 - Installing Fascia .....	3
Section 3 - Dual Roller Surface Headbox Installation.....	4
Section 4 - Pocket Headbox Installation .....	5
Section 5 - Installing Closure Panel.....	6
Section 6 - Limit Switch Adjustments .....	7
Section 7 - Electrical Connections.....	7-9
Section 8 - Standard Hardware Dimensions .....	10

If you have any difficulties installing or servicing your Dual Roller Motorized FlexShade®, call your dealer or Draper, Inc.



Draper, Inc. | 411 S. Pearl St. Spiceland, IN 47385  
draperinc.com | 765.987.7999 | 800.238.7999

© 2021 All Rights Reserved | FORM: DR\_FS\_MO\_Standard\_Hardware\_Inst21

PLEASE READ - **Important Installation Information****⚠ Caution:**

1. Inspect all boxes to make sure you have received the proper shades and parts. Controls may be shipped separately, or in same carton as shades.
2. Open cartons lengthwise.
3. Before mounting shades, verify measurements on label provided with shade, and ensure unit is installed at correct width.
4. Before connecting switches, controls, or electrical, ensure that power is turned **OFF**. Wiring indicated in diagram by dashed lines must be completed by an electrician.
5. Do not wire motors in parallel without written permission from Draper®.
6. All endcaps, fascia, pocket headbox, and other hardware must be installed level. Shades must be level and square.
7. **Read the following installation guidelines thoroughly and follow them carefully. Failure to do so may cause product to fall or otherwise fail, and invalidates warranty.**
8. **Installer is responsible for selecting mounting hardware appropriate for site conditions.**

PLEASE READ - **Safety Information****Important Safety Information****WARNING****Important Safety Information**

**Improper installation and use of the Dual Roller Motorized FlexShade® can result in serious injury or death. Primarily, injuries can occur if the unit falls due to imprecise installation, mishandling of the unit during installation or installation on an insufficient wall or ceiling structure. Please use extreme care.**

1. Please read the following installation guidelines thoroughly and follow them carefully. Failure to do so may cause product to fall or otherwise fail, and could result in serious injury.
2. Installation and calibration of the unit should only be performed by an authorized, qualified, and experienced professional. In particular, electrical work and wiring [indicated in diagram by dashed lines] must be completed only by a qualified professional electrician who has read this manual completely and is familiar with the construction and operation of this equipment and the hazards involved.
3. Do not affix the unit to wall or ceilings that have inadequate strength to permanently hold the unit during use. It is the owner's and installer's responsibility to confirm the wall or ceiling to which the unit attaches is sufficient to permanently hold the weight and stress loads of the unit at all times. Draper, Inc., is not responsible for improper installation, application, testing, or workmanship related to the product at place of installation.
4. It is the installer's responsibility to make sure appropriate fasteners are used for mounting.
5. All brackets, fascia, headboxes, pockets, wall clips, and other hardware must be installed level. Unit must be level and square.
6. Never leave the area while operating the unit during installation, maintenance, or normal operation, unless it is secure and safe.
7. Before testing or operation, carefully inspect the entire area and path of the shade and areas underneath the shade to be sure no persons or objects are in the area.
8. Turn off power and any nearby equipment or cables carrying electricity before connecting switches, wires, controls, or electrical components.
9. Make sure the limit switches are pointed down or accessible when placing the motor in brackets/endcaps.
10. All motors should be tested and limits set using test cord before shades are wired.
11. Do not wire motors in parallel without written permission from Draper, Inc.
12. During testing or operation, carefully watch the surrounding area for any potential safety concerns including nearby persons or objects.
13. After installation, the entire system, including all sensors, should be carefully tested to ensure safe and normal operation. Extreme care should be taken during testing to remain clear of moving parts to avoid possible injury.
14. Operation of unit should be performed only by authorized and qualified personnel, who have been trained in the safe and effective operation of the unit and understand its safety features.
15. The safety features of the unit, including sensors, should never be disabled, bypassed, or overridden. The system should not be operated until all safety features, including the sensors, are properly and completely installed, calibrated, and tested.
16. Unit may need to comply with local, state, or district rules and regulations, in particular when installed in schools. All applicable rules and regulations should be reviewed before installation and use.
17. Failure to precisely follow installation guidelines invalidates all warranties.
18. Custom products/installations may not be reflected in this manual. Call Draper, Inc., if you have questions about the installation of custom products or any questions about your installation.

**Before Beginning Installation**

1. Look for any job site conditions that could interfere with installation or operation of the system.
2. Read carefully and be sure to understand all installation instructions and all related operations manuals. These instructions are intended to serve as a guide for the installer and owner. They should be followed closely and combined with the expertise of experienced qualified installers. Draper, Inc., is not responsible for improper installation, application, testing, or workmanship related to the product at place of installation. Please retain all instructions for future use.
3. Open cartons lengthwise.
4. Locate and lay out all pieces.
5. Inspect all boxes to make sure you have received the proper shade and parts. Controls may be shipped separately, or in same carton as shade.
6. If you have any difficulties with installing, servicing, or operating your shade, call your dealer or Draper, Inc., 765-987-7999.

PLEASE READ - **Field Adjustments**

Each Draper Solar Control Shade is tested to ensure proper operation. Even with this testing, some field adjustments may be needed for telescoping.

If the shade is telescoping, place a piece of high quality gaffer tape about 1" (25mm) wide on the exposed roller (*where the fabric will cover it*) on the side that the fabric will be drawn toward. For example: if the fabric is tracking to the left, place the tape on the right side.

PLEASE READ - **Cleaning and Maintenance**

Window covering products manufactured by Draper, when properly installed, should require no operational maintenance or lubrication.

Most standard Draper fabrics may be cleaned at the window by vacuuming with a soft brush attachment. They also may be cleaned by using a sponge or soft cloth and mild solution of warm soapy water. A mild dishwashing liquid is recommended. A clean dry cloth is recommended for the metal finish.

**Please Note:** Exceptions are Flocké and Phifer SW7000® fabrics, which must be cleaned with a dry art sponge. (*SheerWeave® is a registered trademark of Phifer® Incorporated. Flocké® is a registered trademark of Mermet® Incorporated.*)

## Section 1 - Mounting Endcaps (Brackets)

**Please Note:** Installer is responsible for selecting mounting hardware appropriate for site conditions.

1. Snap endcap covers onto endcaps. The proper orientation of **Left-Hand, Right-Hand, Front and Back** is molded into endcap covers (Fig. 1).
2. Mark wall, jamb, or ceiling for placement of mounting endcaps.
3. Drill small starter hole (if necessary) in mounting surface.
4. Mount endcaps using appropriate fasteners for surface.
5. Place operator (motor) end of rear shade into its endcap (Fig. 2).
6. Secure motor plate with the provided clips (Fig. 2).
7. Slide notched pin into idler endcap. Secure with retainer clip and lock into place with rotating idler lock. (Fig. 3)
8. Use cord strap to secure electrical cord to endcap. This will prevent the electrical cord from getting caught on the roller and causing damage to the shade.
9. Repeat with front shade.

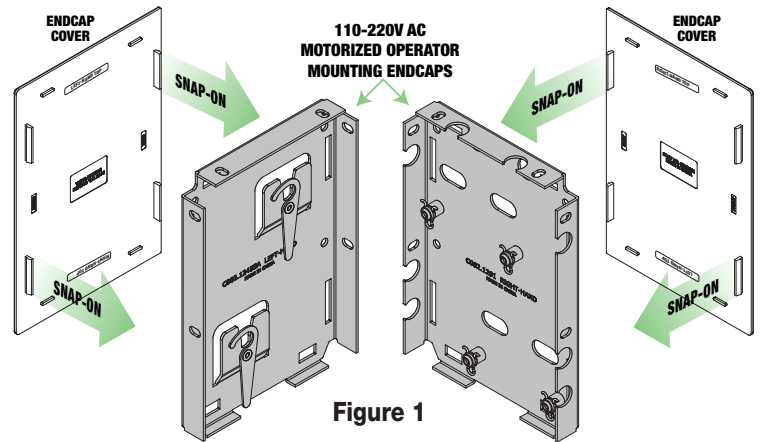

Figure 1

### Operator End

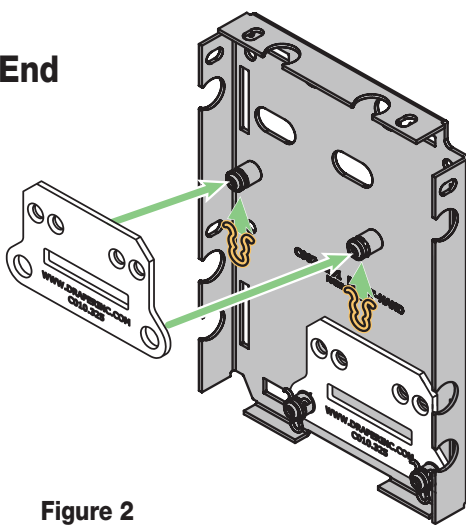

Figure 2

### Idler End

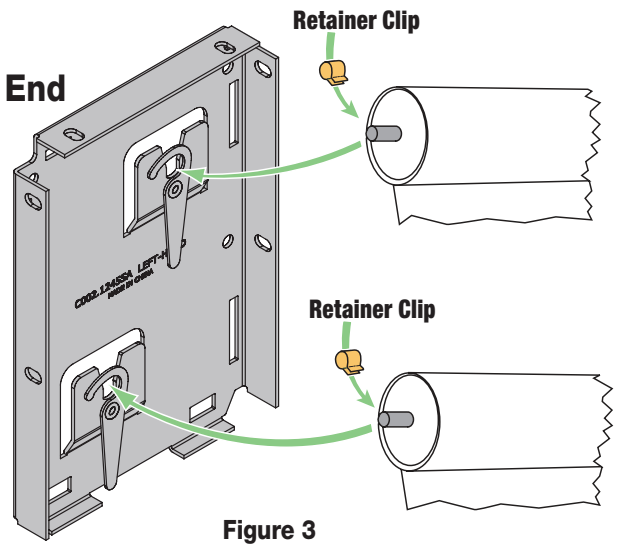

Figure 3

## Section 2 - Installing Fascia

1. Place groove along top of fascia over endcaps, and snap into place (Fig. 4). Fascia is not fully seated until it clicks into place on both ends.
2. Once in place, check for secure fit. If not secure, secure with appropriate fastener (not included).

**PLEASE NOTE: Refer to appropriate sections within this document for different installation options:**

**SECTION 3:**  
Surface Headbox Installation

**SECTION 4:**  
Pocket Headbox Installation

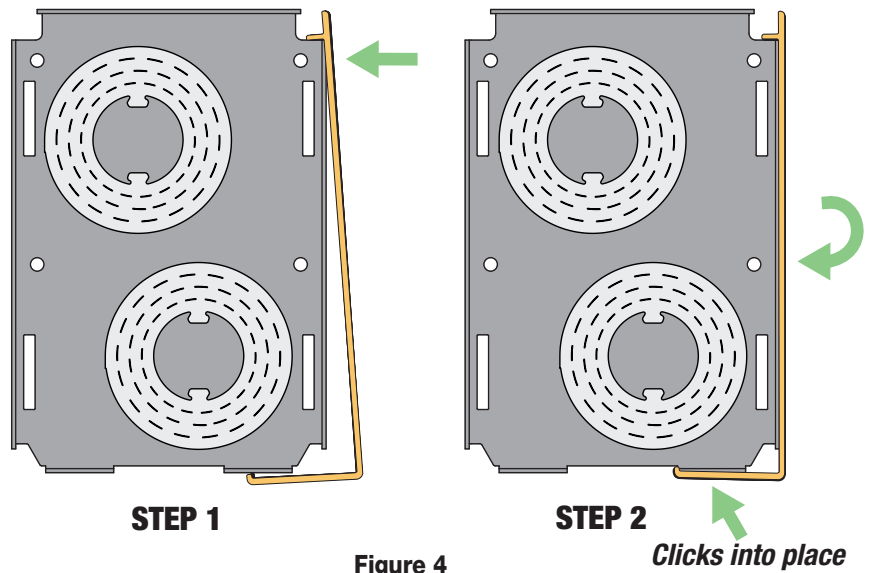
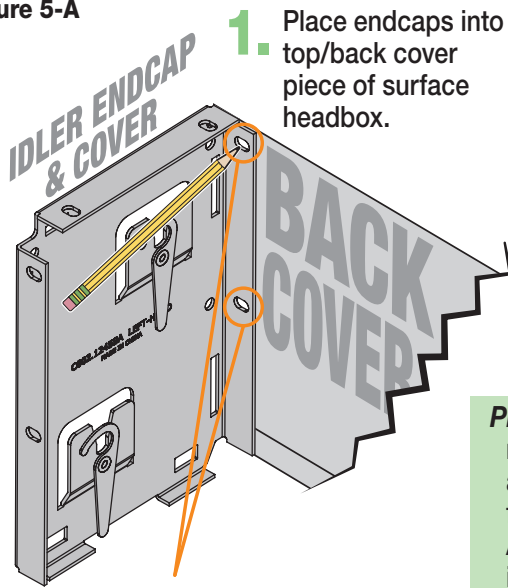

Figure 4

## Section 3 - Dual Roller Surface Headbox Installation

Figure 5-A



1. Place endcaps into top/back cover piece of surface headbox.

2. Using pre-drilled holes in endcaps, mark headbox for drilling.

**Please Note:** Installer must provide adequate clearance for removal of Roller Assembly during installation and maintenance.

Figure 5-B

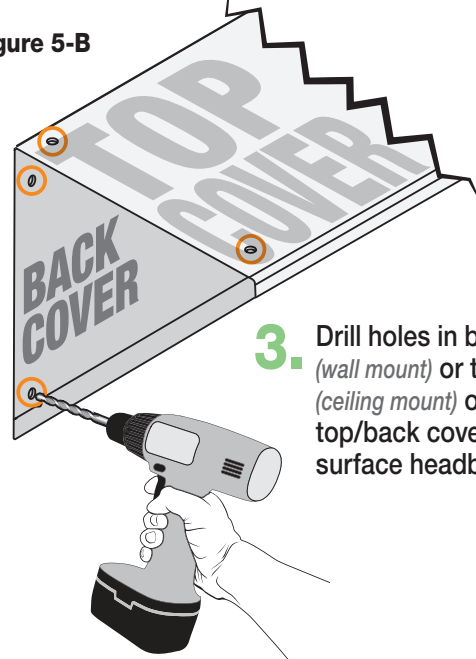

3. Drill holes in back (wall mount) or top (ceiling mount) of top/back cover of surface headbox.

**Please Note:** Headbox MUST BE mounted directly to ceiling or wall, or to a continuous blocking that has been secured to building structure.

Figure 5-C

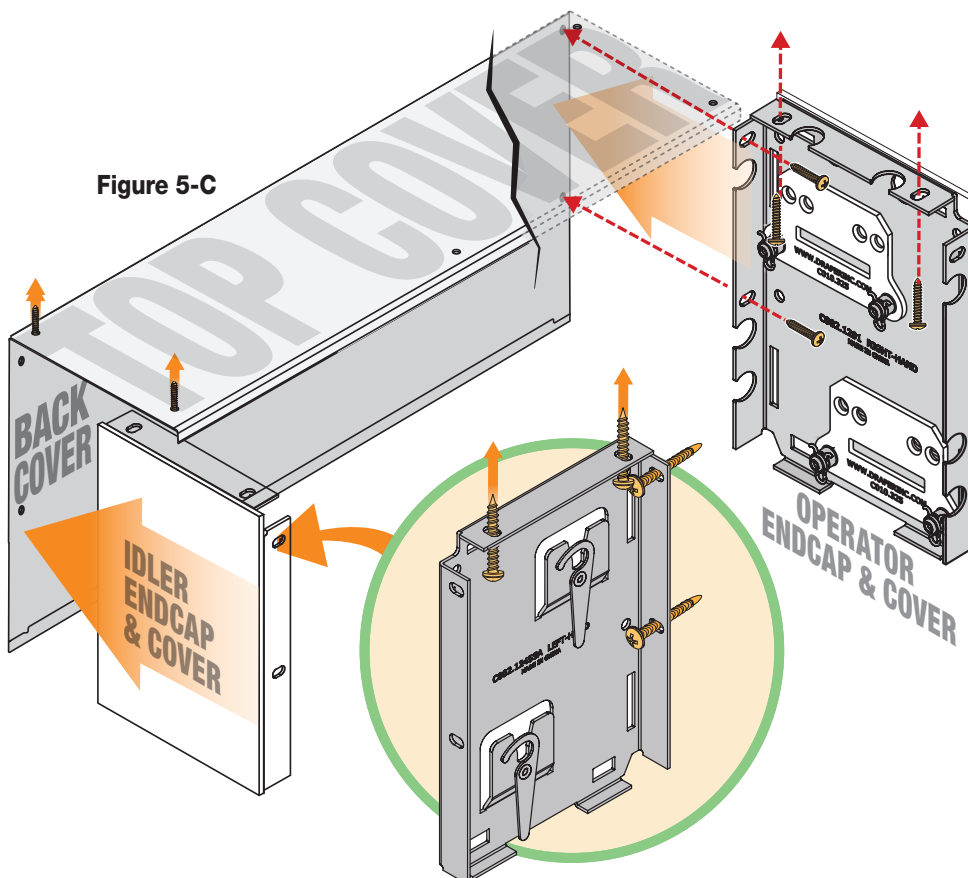

4. Attach endcaps and top/back cover piece to wall or ceiling, using mounting hardware appropriate for site conditions.

**Please Note:** A minimum of two (2) screws is required for each endcap.

Next, mount roller assemblies (Section 4).

## Section 4 - Pocket Headbox Installation

**PLEASE NOTE:** Installer must provide adequate clearance for removal of Roller Assembly during installation and maintenance.

**PLEASE NOTE:** Headbox must be mounted directly to ceiling, or to a continuous blocking that is secured to building structure.

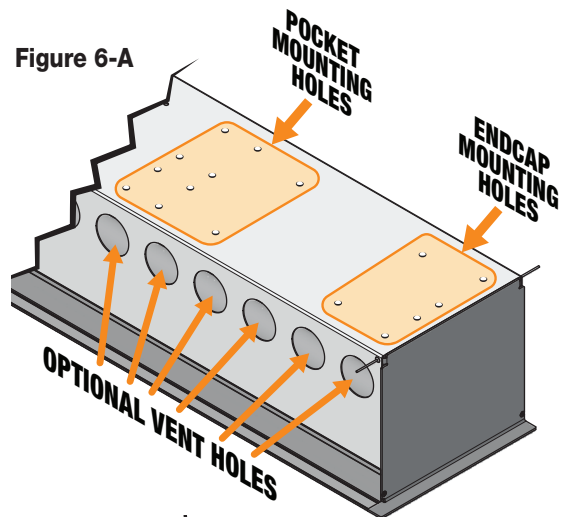
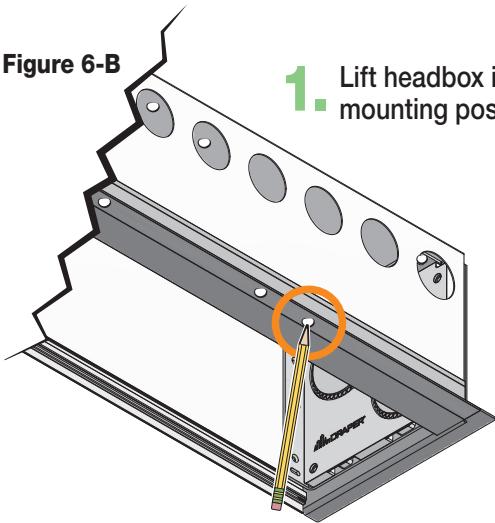

Figure 6-B

1. Lift headbox into mounting position.



2. Mark location of optional pre-drilled pocket mounting holes and endcap mounting holes on top side of headbox on mounting surface.

3. Drill small starter hole (if necessary) in mounting surface.

Figure 6-C

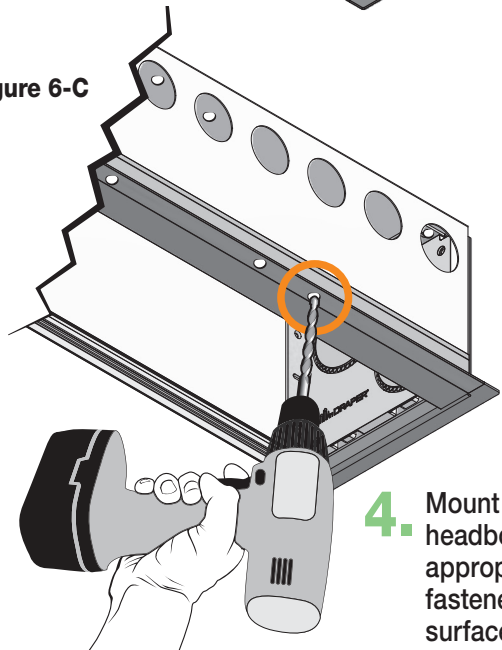

4. Mount pocket headbox using appropriate fasteners for surface.

Figure 6-D

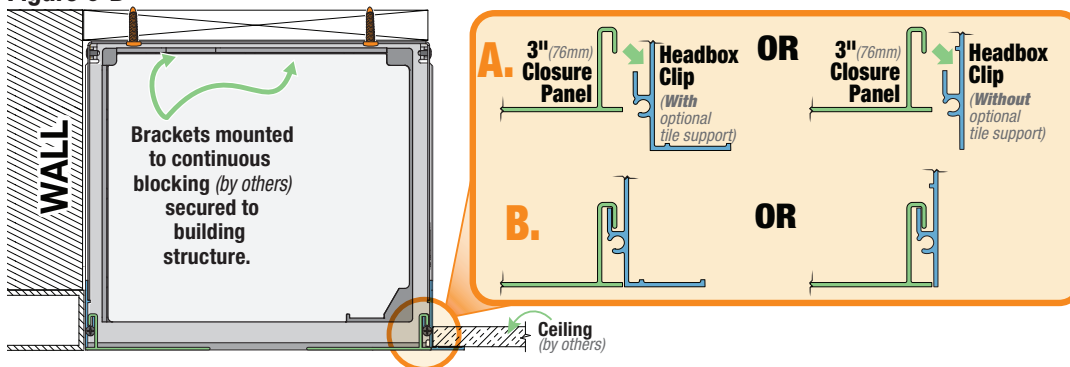

5. Mount endcaps using appropriate fasteners for surface (Section 1).

6. Mount pocket closure. (Fig. 6-D).

Figure 7

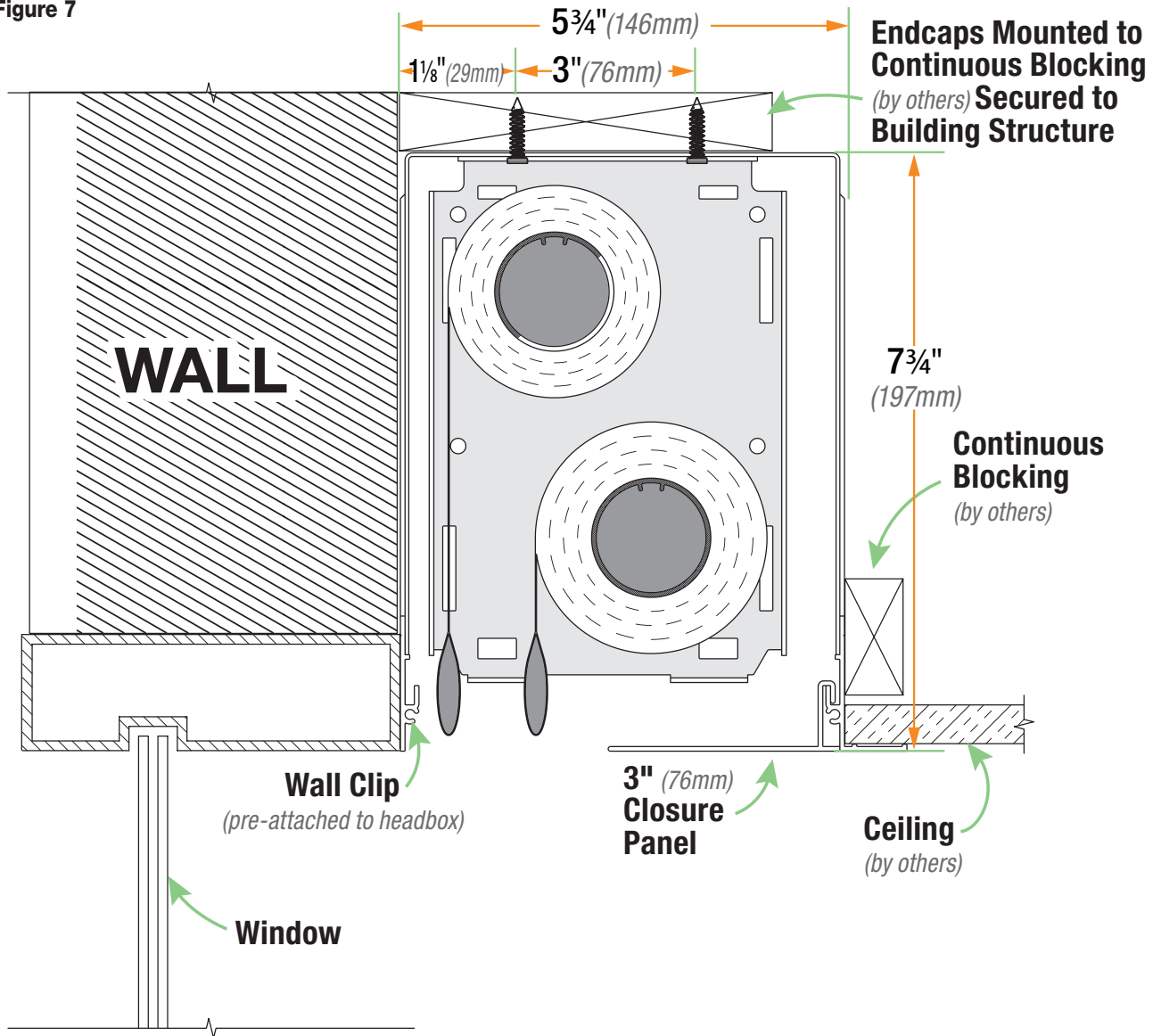

Section 5 - Installing Closure Panel

Follow Steps 1–2 (see Fig. 8)

Figure 8

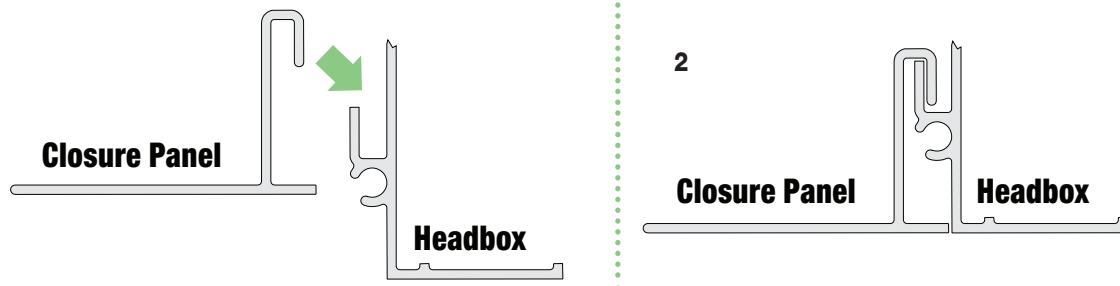

## Section 6 - Limit Switch Adjustments

### Section 8.1 - Standard and Quiet Motors (All procedures shown are for Standard Roll. Invert orientation for Reverse Roll)

#### Section 8.1.1- Push Button Limits

1. Fully depress both limit switch push buttons, then operate wall switch to make sure system works properly.
2. Raise shade to desired “up” stop position.
3. Set upper limit by depressing proper (*back*) push button.
4. Lower shade to desired “down” stop position.
5. Set lower limit by depressing proper (*front*) push button.

#### Section 8.1.2 - Screw-Type Limits

1. Determine which direction of fabric travel corresponds with arrows on motor.
2. Operate shade to desired “down” stop position. Set limit by turning proper socket toward “+” to lower limit, and “-” to raise it.
3. Operate shade to desired “up” stopping position. Set limit by turning proper screw toward “-” to raise limit, and “+” to lower it.

#### ⚠ Caution:

- Be sure all switches are in “off” position before adjusting limit switches.
- Be prepared to shut off manually while testing.
- Shade may be damaged by running shade fabric down too far to expose roller.
- If using a group control system, each limit switch must be set prior to connecting to system.
- Motor must be installed so limit switches are pointed down.

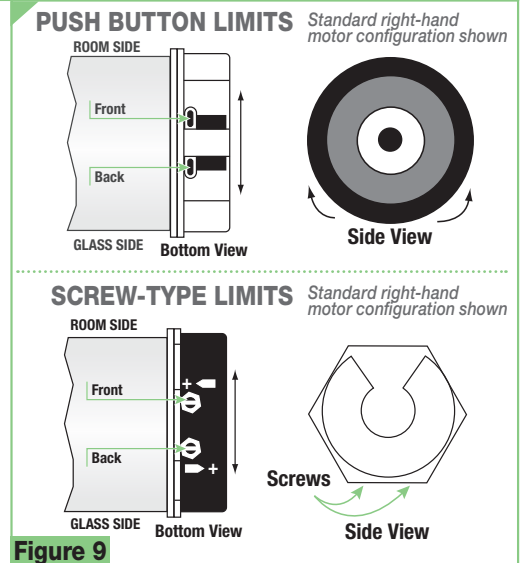

### Section 8.2 - Limit Adjustments: RS485 Motors

For limit setting instructions on these motors, see instructions packaged with the RS485 Address/Limit Setting Tool (part# C156.241).

### Section 8.3 - Limit Switch Adjustments: RTS Motors

For limit setting instructions on these motors, see Radio Frequency Remote Control Programming Instructions (FS\_MO\_RFRC\_ProgInst).

### Section 8.4 - Limit Switch Adjustments: IntelliFlex I/O Motors

For limit setting instructions on these motors, see instructions packaged with the Motor Limit Setting Tool (part# C202.030).

## Section 7 - Electrical Connections

Shade operates on 110-120V, 60 Hz. current. Shade is shipped with internal wiring complete and control switch(es) fully boxed, and standardly supplied with a 6' (1.8 m) cable lead. Longer lead can be substituted by removing two screws in motor end of roller, removing lead, plugging new lead in, and replacing screws. Wire to connect shade to switch(es) and switch(es) to power supply should be furnished by installer.

Connections should be made in accordance with attached wiring diagram, and wiring should comply with national and local electrical codes. DO NOT wire motors in parallel without written permission from Draper®.

**All operating switches should be “off” before power is connected.**

**Please Note:** For low-voltage wiring requirements, Draper recommends consulting with a professional low-voltage electrical contractor. It is very important that shielded and stranded CAT 5 cable be used to prevent any electrical interference.

**Please Note:** A Draper Motor Test Cable (Part# 503109) and M12 Pigtail (Part# C107.089.60) are available for temporary power for testing and limit setting.

**⚠ IMPORTANT:** To reduce the risk of electric shock, equipment that features a grounding type attachment plug has a third (*grounding*) pin on the attachment plug. This plug will **ONLY** fit into a grounding type outlet. If the plug does not fit into the outlet, a qualified electrician must install the proper outlet. Do not change the plug in any way. Do not use an extension cord. If the power supply cord is too short, a qualified electrician must install an outlet near the drapery operator.

## Section 7 - Electrical Connections (Continued)

### Controls & System Overview

Sonesse® 120VAC Motors

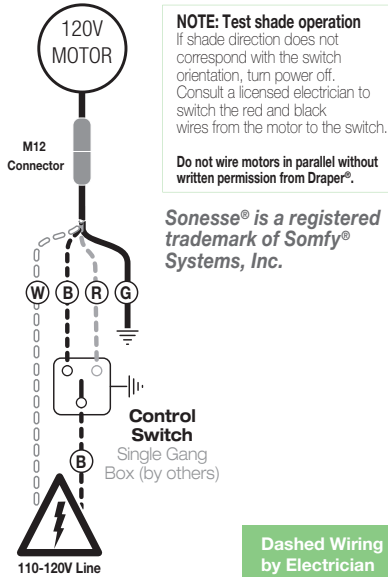

### Controls & System Overview

Sonesse® RTS 120VAC Motors

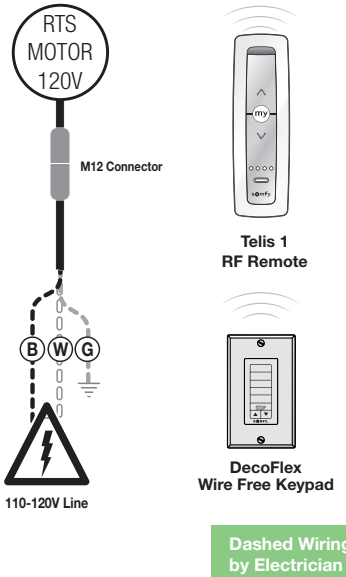

### M12 Connector for 4-Wire Motors

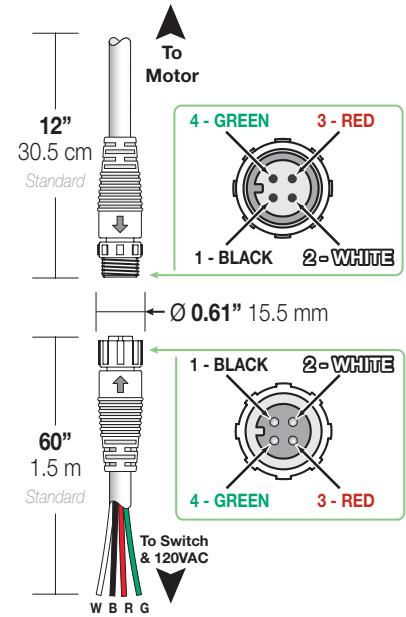

### M12 Connector for 3-Wire Motors

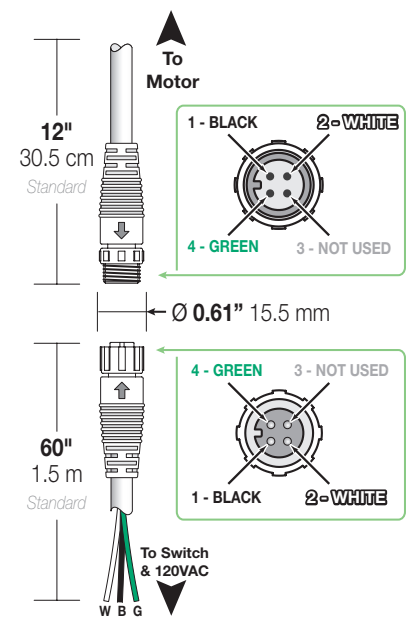

### Controls & System Overview

Sonesse® 485 120VAC Motors

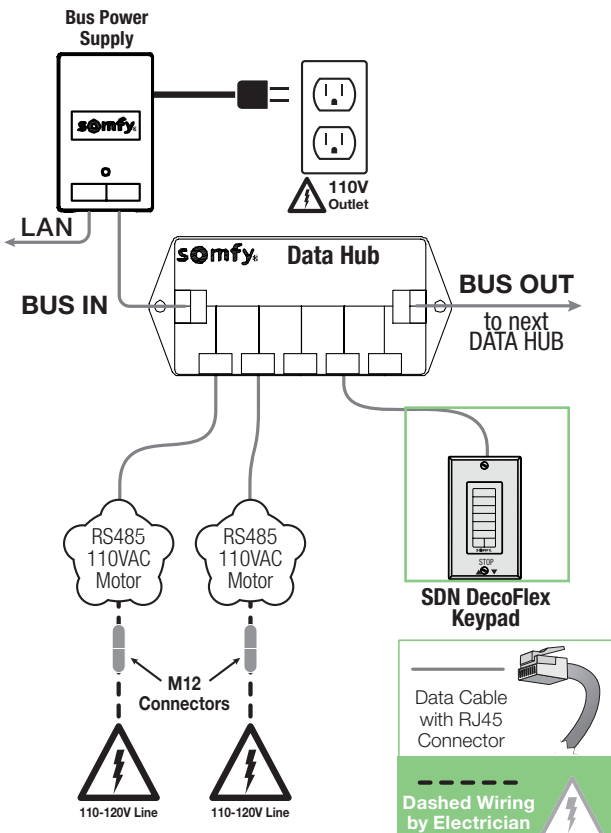



## Controls & System Overview IntelliFlex I/O 120VAC Motors

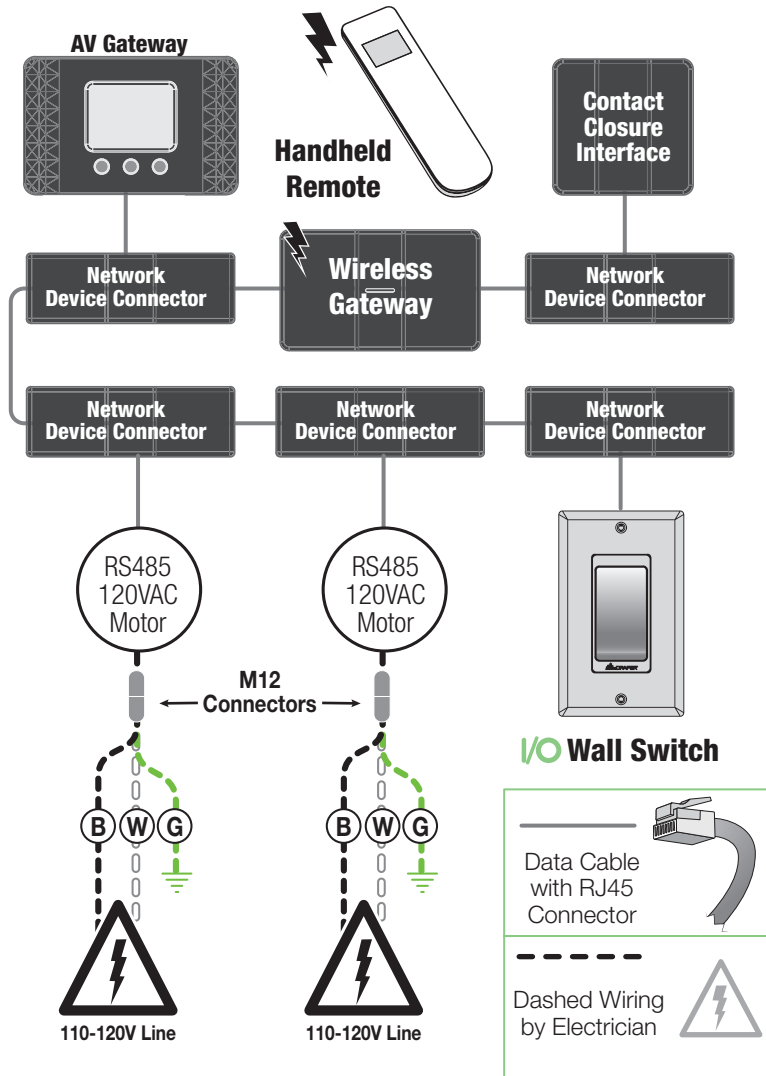

### Data Cable Pin-Out - RJ45 Connector

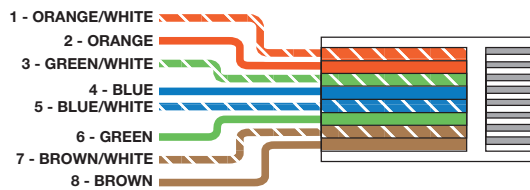

## Section 8 - Standard Hardware Dimensions

### Endcap & Fascia Dimensions

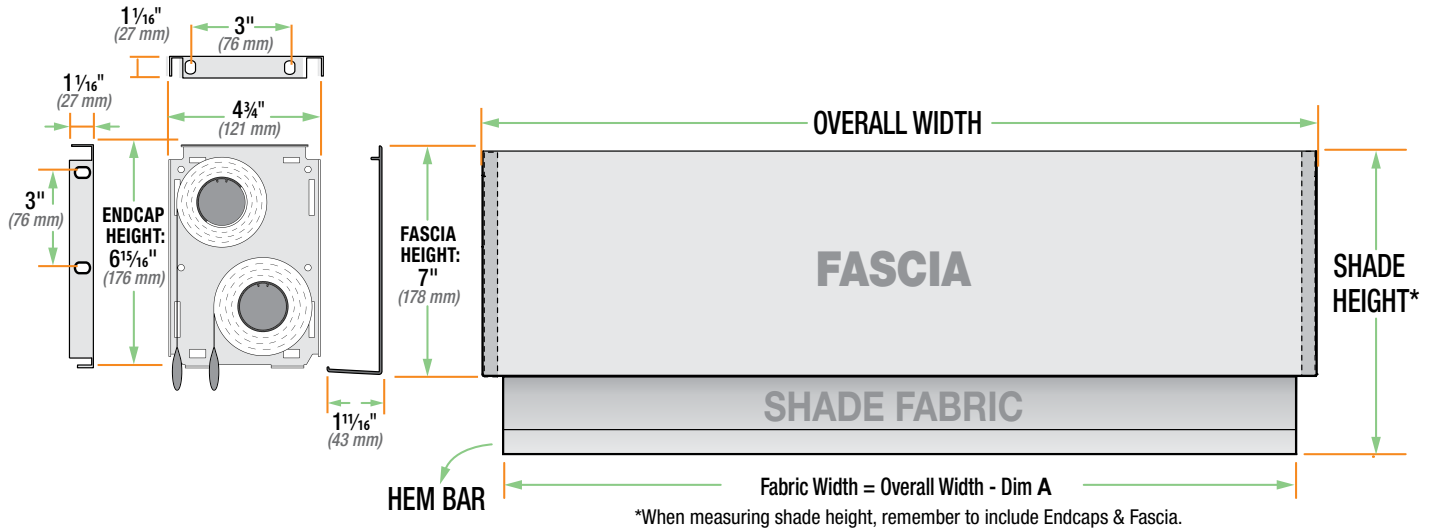

### Dual Roller Surface Headbox Dimensions

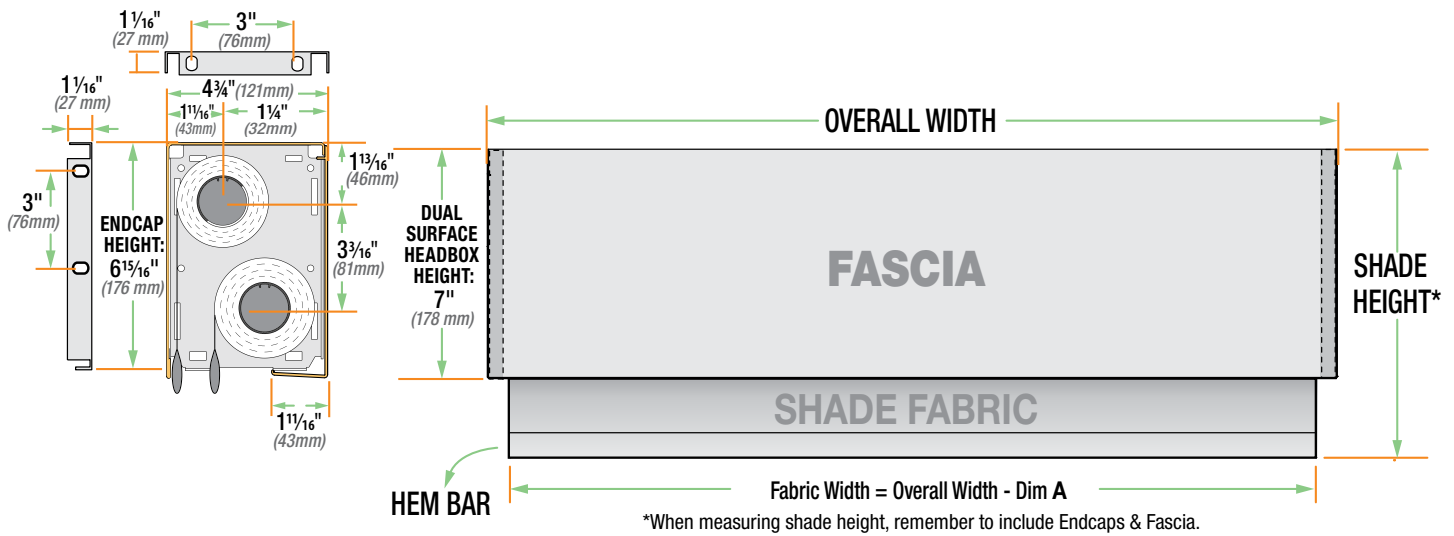

### Dual Roller Pocket Headbox Dimensions

#### Standard Dual Roller Pocket Headbox Dimensions

