

FlexStyle™ Ascend

Cordless operated open roll shade



SUBMITTAL TECHNICAL INFO

FLSTYLE ASCEND

Please check all appropriate selections and attach room schedule with verified dimensions.

Fabric Series: _____

Color Name / Number: _____

Openness Factor: _____

Please see [Draper® Fabric Options](#) for fabric colors and specifications.

Specifications

EQUIPMENT

SPRING OPERATOR: Balanced spring mechanism with metal roller. Adjuster ring built into the spring mechanism allows for finite adjustment of the torque output of the mechanism by turning it clockwise or counterclockwise. A built-in limiter prevents over extension of the spring mechanism.

COMPONENTS

ROLLERS: Fabricated from extruded aluminum, galvanized steel, or enameled steel. Diameter, wall thickness, and material selected by manufacturer to accommodate shade type and size. Minimum roller diameter 1.5 inches. Dia. X .062" wall (38 mm x 1.6 mm).

MOUNTING BRACKETS

BRACKETS: Made of .080 die cast aluminum. Can be wall or ceiling mounted. No exposed fasteners.

FINISHES AVAILABLE: Black, Bronze Plated, Brushed Gold Plated, Brushed Nickel Plated, Chrome Plated, Grey, Taupe, White, Warm White, Grey Primer.

ROLLER IDLER ASSEMBLY: Nylon with spring-loaded pin to interlock with mounting bracket.

HEM BAR:

OPEN POCKET ELLIPTICAL SLAT: 1 inch (25mm) aluminum elliptical slat with plastic ends inside of a 1 3/8 inch (41mm) pocket.

DOWNLOADABLE 3-PART SPECIFICATIONS:

www.draperinc.com

Please note: Dimensions of rollers, operators, and hardware at manufacturer's discretion.

Available Sizes:

WIDTH:	1'	2'	3'	4'	5'	6'	7'	8'
HEIGHT								
2'								
3'								
4'								
5'								
6'								
7'								
8'								
9'								
10'								

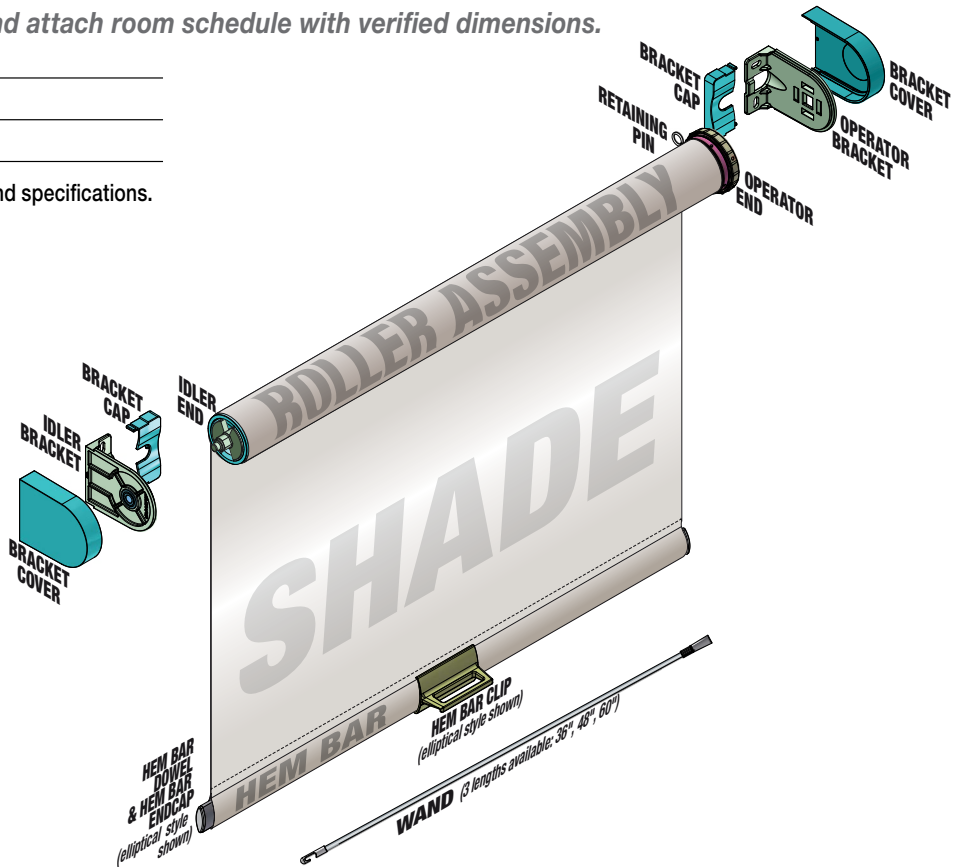

Select Bracket Options

- Select Operator Location (front view)
- Right (standard)
 - Left (reverse roll ONLY)

Plated Bracket Colors

- Brushed Nickel
- Brushed Gold
- Antique Bronze
- Chrome

Matt Painted Bracket Colors

- Black
- White
- Grey
- Taupe
- Warm White
- Grey Primer (to be painted by others)

Select Optional Accessories

- Pull-Down Wand (available in White only)
 - 36"
 - 48"
 - 60"
- Hem Bar Clip

WARNING: Ascend operator should not be used with products or pockets having a bottom closure without written permission from Draper.

PROJECT: _____

ARCHITECT: _____

CONTRACTOR: _____

SUPPLIER: _____

DATE: _____ REVISED: _____



Draper, Inc. | 411 S. Pearl St. Spiceland, IN 47385
draperinc.com | 765.987.7999 | 800.238.7999

© 2024 All Rights Reserved | FORM: FlexStyle_Ascend_Sub24

Bracket Dimensions

C002.1822 (Idler End, Extended)

C002.1820 (Motor End, Extended)

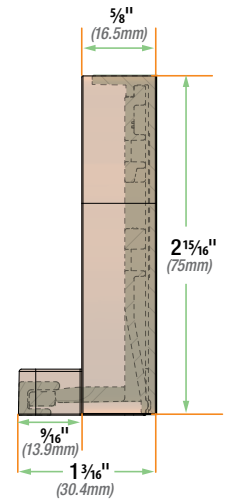
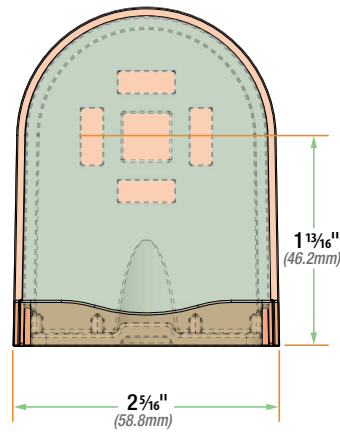
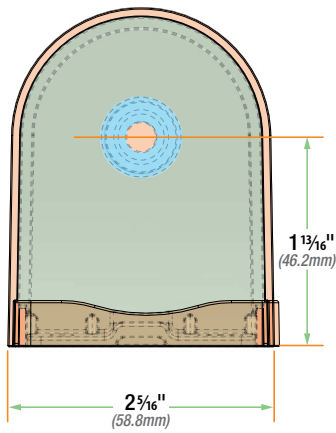
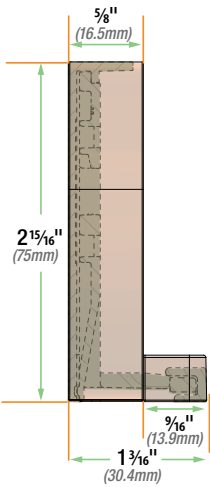
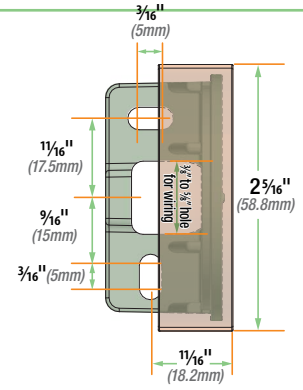
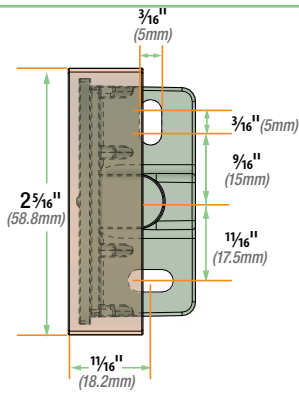

Shade Dimensions

