

Dual Roller Coupled Motorized FlexShade® (Standard Hardware)



INSTRUCTIONS INSTALLATION & OPERATION

Overview - Components

FLEXSHADE F*MO

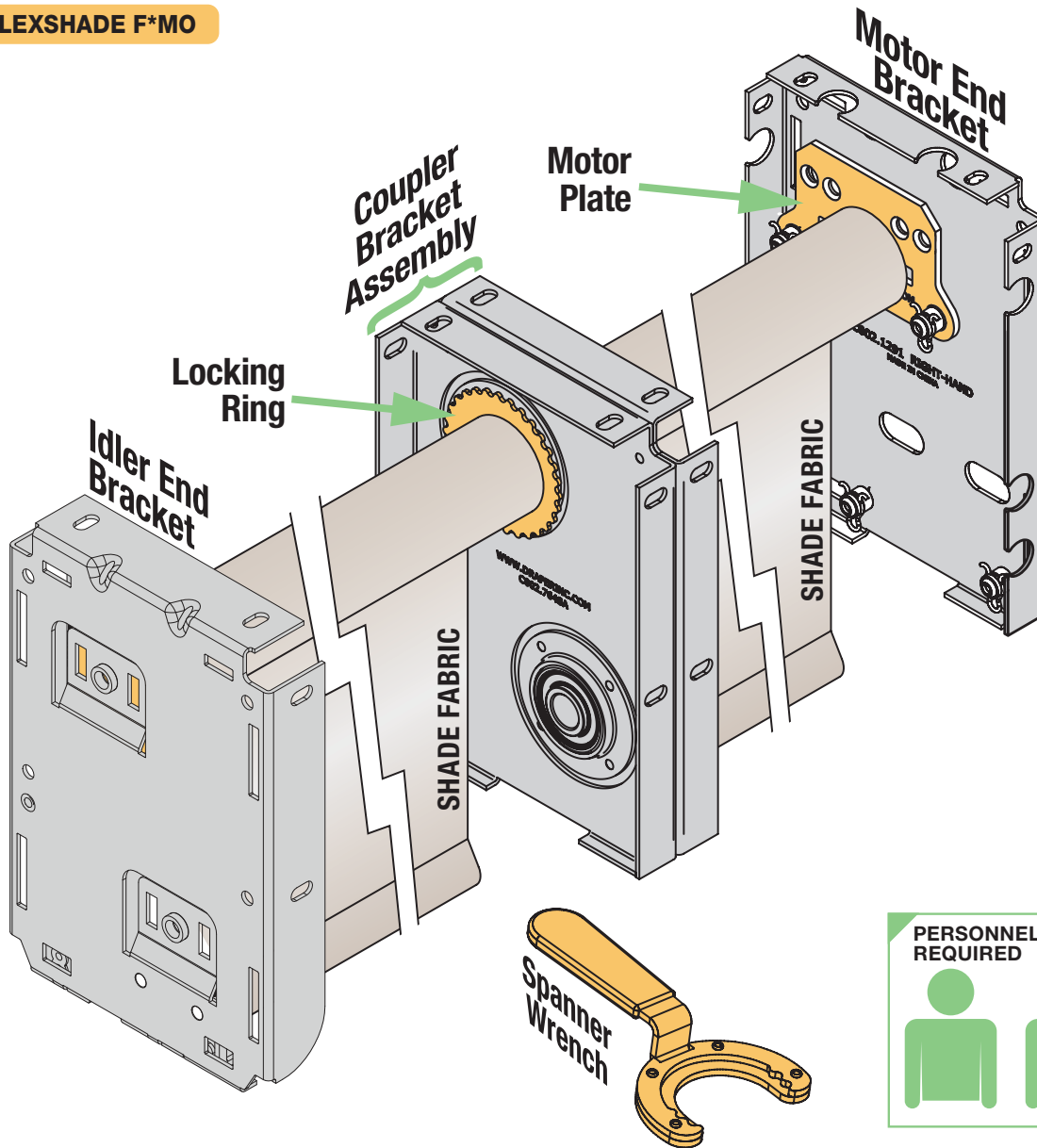

TOOLS REQUIRED



PENCIL



POWER DRILL

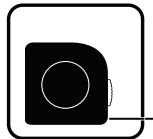

TAPE MEASURE

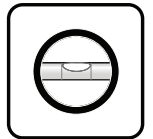

LEVEL



HARDWARE (by others)



PLIERS

PERSONNEL REQUIRED

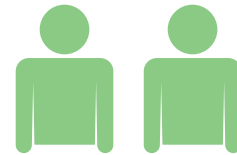

⚠ CAUTION ⚠

Read and understand all warnings (Page 2 of this document) before beginning installation.

Contents

Overview - Components.....	1	Section 4 - Dual Roller Surface Headbox Installation.....	6
PLEASE READ - Important Safety and Installation Information	2	Section 5 - Pocket Headbox Installation	7
PLEASE READ - Field Adjustments, Cleaning and Maintenance.....	2	Section 6 - Fabric/Roller Assembly Alignment	8
Section 1 - Idler-End and Operator End Assemblies	3	Section 7 - Limit Switch Adjustments	9
Section 2 - Mounting / Assembly.....	4	Section 8 - Electrical Connections.....	9-10
Section 3 - Fascia Attachment.....	5	Section 9 - Dimensions	11-12

If you have any difficulties installing or servicing your Dual Roller Coupled Motorized FlexShades®, call your dealer or Draper, Inc.



Draper, Inc. | 411 S. Pearl St. Spiceland, IN 47385
draperinc.com | 765.987.7999 | 800.238.7999

© 2021 All Rights Reserved | FORM: Coupled_DR_FS_MO_Standard_Hardware_Inst21

PLEASE READ - **Important Installation Information****⚠ Caution:**

1. Inspect all boxes to ensure you have received the proper shades and parts. Controls may be shipped separately, or in same carton as shades.
2. Open cartons lengthwise.
3. Before mounting shades, verify measurements on label provided with shade, and ensure unit is installed at correct width.
4. Before connecting switches, controls, or electrical, ensure that power is turned **OFF**. Wiring indicated in diagram by dashed lines must be completed by an electrician.
5. Do not wire motors in parallel without written permission from Draper.
6. All endcaps, fascia, pocket headbox, and other hardware must be installed level. Shades must be level and square.
7. **Read the following installation guidelines thoroughly and follow them carefully. Failure to do so may cause product to fall or otherwise fail, and invalidates warranty.**
8. **Installer is responsible for selecting mounting hardware appropriate for site conditions.**

PLEASE READ - **Safety Information****Important Safety Information****WARNING****Important Safety Information**

Improper installation and use of the Dual Roller Coupled Motorized FlexShade® can result in serious injury or death. Primarily, injuries can occur if the unit falls due to imprecise installation, mishandling of the unit during installation or installation on an insufficient wall or ceiling structure. Please use extreme care.

1. Please read the following installation guidelines thoroughly and follow them carefully. Failure to do so may cause product to fall or otherwise fail, and could result in serious injury.
2. Installation and calibration of the unit should only be performed by an authorized, qualified, and experienced professional. In particular, electrical work and wiring [indicated in diagram by dashed lines] must be completed only by a qualified professional electrician who has read this manual completely and is familiar with the construction and operation of this equipment and the hazards involved.
3. Do not affix the unit to wall or ceilings that have inadequate strength to permanently hold the unit during use. It is the owner's and installer's responsibility to confirm the wall or ceiling to which the unit attaches is sufficient to permanently hold the weight and stress loads of the unit at all times. Draper®, Inc., is not responsible for improper installation, application, testing, or workmanship related to the product at place of installation.
4. It is the installer's responsibility to ensure appropriate fasteners are used for mounting.
5. All brackets, fascia, headboxes, pockets, wall clips, and other hardware must be installed level. Unit must be level and square.
6. Never leave the area while operating the unit during installation, maintenance, or normal operation, unless it is secure and safe.
7. Before testing or operation, carefully inspect the entire area and path of the shade and areas underneath the shade to be sure no persons or objects are in the area.
8. Turn off power and any nearby equipment or cables carrying electricity before connecting switches, wires, controls, or electrical components.
9. Ensure the limit switches are pointed down or accessible when placing the motor in brackets/endcaps.
10. All motors should be tested and limits set using test cord before shades are wired.
11. Do not wire motors in parallel without written permission from Draper, Inc.
12. During testing or operation, carefully watch the surrounding area for any potential safety concerns including nearby persons or objects.
13. After installation, the entire system, including all sensors, should be carefully tested to ensure safe and normal operation. Extreme care should be taken during testing to remain clear of moving parts to avoid possible injury.
14. Operation of unit should be performed only by authorized and qualified personnel, who have been trained in the safe and effective operation of the unit and understand its safety features.
15. The safety features of the unit, including sensors, should never be disabled, bypassed, or overridden. The system should not be operated until all safety features, including the sensors, are properly and completely installed, calibrated, and tested.
16. Unit may need to comply with local, state, or district rules and regulations, in particular when installed in schools. All applicable rules and regulations should be reviewed before installation and use.
17. Failure to precisely follow installation guidelines invalidates all warranties.
18. Custom products/installations may not be reflected in this manual. Call Draper, Inc., if you have questions about the installation of custom products or any questions about your installation.

Before Beginning Installation

1. Look for any job site conditions that could interfere with installation or operation of the system.
2. Read carefully and be sure to understand all installation instructions and all related operations manuals. These instructions are intended to serve as a guide for the installer and owner. They should be followed closely and combined with the expertise of experienced qualified installers. Draper, Inc., is not responsible for improper installation, application, testing, or workmanship related to the product at place of installation. Please retain all instructions for future use.
3. Open cartons lengthwise.
4. Locate and lay out all pieces.
5. Inspect all boxes to ensure you have received the proper shade and parts. Controls may be shipped separately, or in same carton as shade.
6. If you have any difficulties with installing, servicing, or operating your shade, call your dealer or Draper, Inc., 765-987-7999.

PLEASE READ - **Field Adjustments**

Each Draper Solar Control Shade is tested to ensure proper operation. Even with this testing, some field adjustments may be needed for telescoping.

If the shade is telescoping, place a piece of high quality gaffer tape about 1" (25mm) wide on the exposed roller (*where the fabric will cover it*) on the side that the fabric will be drawn toward. For example: if the fabric is tracking to the left, place the tape on the right side.

PLEASE READ - **Cleaning and Maintenance**

Window covering products manufactured by Draper, when properly installed, should require no operational maintenance or lubrication.

Most standard Draper fabrics may be cleaned at the window by vacuuming with a soft brush attachment. They also may be cleaned by using a sponge or soft cloth and mild solution of warm soapy water. A mild dishwashing liquid is recommended. A clean dry cloth is recommended for the metal finish.

Please Note: Exceptions are Flocké and Phifer SW7000® fabrics, which must be cleaned with a dry art sponge. (*SheerWeave® is a registered trademark of Phifer Incorporated. Flocké® is a registered trademark of Mermet® Incorporated.*)

Section 1 - Idler-End and Operator End Assemblies

Please Note: The operator will already be installed in the operator-end roller; the sliding pin idler will also be installed in the idler-end roller. It is only necessary to install the coupler assemblies.

2" (51 mm) Idler-End Assembly

Please Note: Notches in the tube need to be lined up with the "keys" on the couplers.

1. Insert coupler assembly into roller. Making sure the notch in the tube is lined up with the "key" on the coupler, press until the assembly is fully seated in the roller.

⚠ Caution:

- Ensure the locking ring on the idler-end coupler assembly is fully tightened before installing roller into brackets. There should be no play in the locking ring. If the locking ring is loose, then the idler is in "height adjustment" mode.
- Wear a heavy glove on the hand used to grip the locking ring.
- Tighten the locking ring until it is fully locked and it cannot rotate any further. Check to ensure it is tight and will not work loose. If locking ring cannot be tightened by hand, use a flat screwdriver or other tool to assist.

2" (51 mm) Operator-End Assembly

Please Note: Operator-end coupler assemblies will not slide straight into the roller tube.

1. Insert assembly into the roller, with the "key" slightly off center from the notch.
2. Once assembly is far enough in that the ribs are past end of the notch, rotate the coupler until the notch is lined up with the "key" on the coupler.

Please Note: If the assembly will not fully seat in the roller, retract the shaft (if applicable) and tap the assembly with a rubber mallet. Be careful not to damage the coupler.

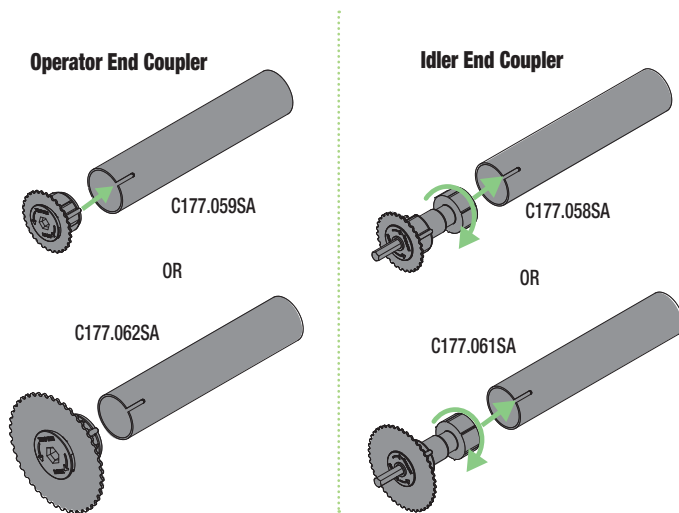

Figure 1a

Please Note: The retractable shaft must point toward the opposite end of the motor and oriented in that direction for the entire unit.

3" (76 mm) Idler-End Assembly

Please Note: The retractable shaft needs to be pointing toward the opposite end of the motor and oriented that direction for the whole unit.

1. Insert coupler assembly adapter into roller. Making sure the notch in the adapter is lined up with the notch in the coupler, press until the adapter is fully seated in the roller.
2. Insert coupler assembly into adapter. Making sure the notch in the inside of the adapter is lined up with the "key" on the coupler, press until the assembly is fully seated.

⚠ Caution:

- Ensure the locking ring on the idler-end coupler assembly is fully tightened before installing roller into brackets. There should be no play in the locking ring. If the locking ring is loose, then the idler is in "height adjustment" mode.
- Wear a heavy glove on the hand used to grip the locking ring.
- Tighten the locking ring until it is fully locked and it cannot rotate any further. Check to ensure it is tight and will not work loose. If locking ring cannot be tightened by hand, use a flat screwdriver or other tool to assist.

3" (76 mm) Operator-End Assembly

1. Follow the same steps used for the idler-end.

Please Note: If the assembly will not fully seat in the roller, retract the shaft (if applicable) and tap the assembly with a rubber mallet. Be careful not to damage the coupler.

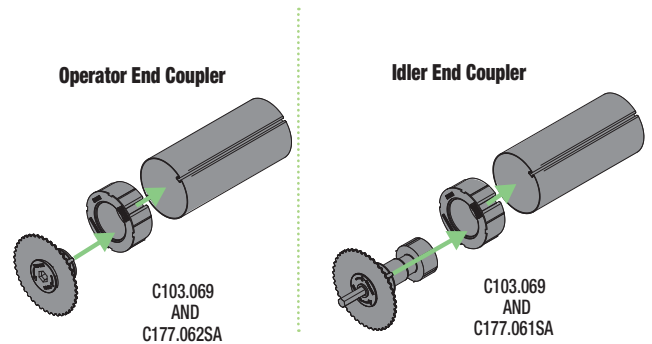
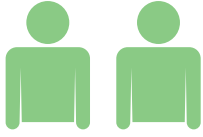

Figure 1b

Please Note: The retractable shaft must point toward the opposite end of the motor and oriented in that direction for the entire unit.

Section 2 - Mounting / Assembly (Requires two (2) installers)

PERSONNEL REQUIRED



⚠ Caution: Installation of this product requires two people.

⚠ Caution: Before beginning installation, practice extending and retracting the coupler shaft in a fabric/roller assembly, following instructions in the "Operating the Retractable Coupler Shaft" section below.

⚠ Caution: All motors should be tested and limits set using test cord before electrician wires shade.

Please Note: Custom products/installations may not be reflected by this document. Call Draper, Inc. with any questions about product installation.

Section 2.1 - Operating the Retractable Coupler Shaft (Fig. 2)

Please Note: Custom products/installations may not be reflected by this document.

Draper® Coupled FlexShades utilize a locking retractable shaft (Fig. 1) to hold roller assemblies in place and link panels together. The retractable coupler shaft on has three distinct positions: fully extended, intermediate, and fully retracted.

1. To retract the coupler shaft from fully extended to the intermediate position, grasp the roller with one hand while rotating the metal ring counterclockwise (as viewed facing the coupler assembly) approximately ½ of a turn with the other; this will leave the shaft extended approximately ½" (13mm).
2. To retract the coupler shaft fully, rotate the metal ring counterclockwise (as viewed facing the coupler assembly) an additional ½ of a turn.
3. To lock shaft in place when extended, rotate metal ring clockwise ¼ turn.

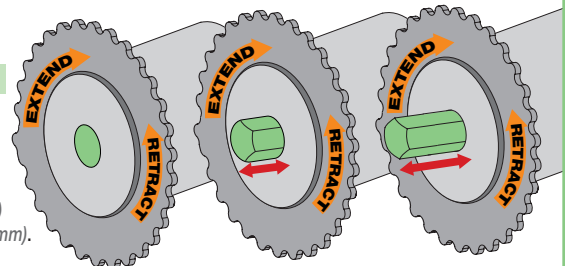

Figure 2

Please Note: There is no retractable shaft in the idler end assembly on the idler end shade (furthest from the operator). This idler assembly utilizes a sliding pin and retainer clip.

Please Note: These instruction steps are for installing endcaps/brackets one at a time. Brackets/endcaps may also all be installed at the same time, prior to installing roller/fabric assemblies. If brackets/endcaps are installed first, please be certain of measurements and locations. For best results, assemble the unit on a flat, clean surface and verify measurements before attaching brackets/endcaps.

Section 2.2 - Operator-end Bracket Assembly (Fig. 3)

1. Before mounting shades, verify measurements on the card provided with the shade, and ensure the brackets are installed at the correct width.
2. Measure and mark wall, jamb, or ceiling for placement of mounting brackets or endcaps. Mark a level line across all windows to ensure a level installation. Mark the outer edges of the operator- and idler-end brackets or endcaps, and the center locations of the coupler brackets. Locations are determined by:
 - A. Operator-end panel width;
 - B. Intermediate panel width(s); and
 - C. Idler-end panel width.
3. Mount the operator-end bracket assembly (Fig. 3 for bracket/endcap types). Ensure the outside edge is aligned with the marked location.

Please Note: Installer is responsible for selecting mounting hardware appropriate for site conditions.

Figure 3

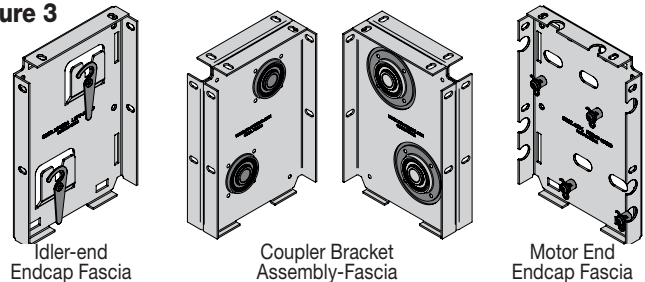

⚠ Caution: During installation and adjustment of coupled shades, fingers may slip, causing possibly severe cuts and/or scrapes. Wear gloves that are flexible enough to adjust the metal wheel but strong enough to prevent scrapes from surrounding metal or other surfaces.

Section 2.3 - First (Operator-end) Fabric Roller Assembly (Fig. 4)

1. If desired, the proper location of the coupler bracket assembly can be verified. Otherwise, proceed to step 2.
 - A. Installer #1 attaches the operator end to the operator-end bracket.
 - B. Installer #2 slides the coupler bracket onto the coupler shaft of the fabric/roller assembly to be installed, and holds in place.
 - C. Verify and mark location and set fabric/roller assembly aside.
2. Install first coupler bracket assembly to mounting surface.
3. Ensure the operator-end fabric/roller assembly's coupler shaft is completely retracted (see "Operating the Retractable Shaft" and Fig. 2).
4. Raise rear/upper fabric/roller assembly into place. While Installer #1 inserts the operator end of fabric/roller assembly into the operator-end bracket, Installer #2 lifts the coupler end up next to the coupler bracket assembly, then extends the coupler shaft to the intermediate position by rotating the ring clockwise about ½ of a turn (see "Operating the Retractable Shaft" and Fig. 2). This will hold the first unit in place during installation of the next panel.
5. For motorized shades, connect power so the shade can be operated and adjusted.
6. Operate the shade to ensure proper fabric tracking and to set up and down limits (see sections on limit adjustment and field adjustments).
7. Raise shade to upper limit.

Figure 4

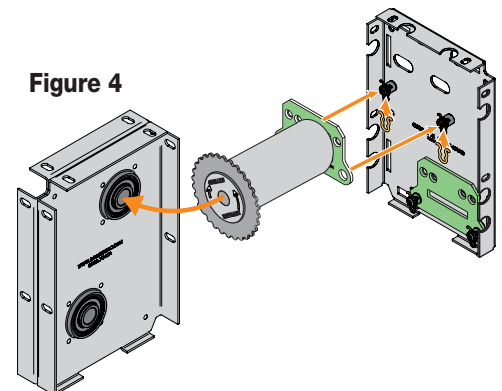

Section 2.4 - Intermediate Fabric/Roller Assembly (Fig. 5)

Please Note: Skip this section if your unit only has two panels

1. If desired, the proper location of the next bracket can be verified. Otherwise, proceed to step 2.
2. Install the next coupler bracket to mounting surface.
3. The end of the previously-installed coupler shaft should be flush with the outside edge of the bearing. If it is extended beyond the bearing, you can retract the coupler shaft of the previously installed roller to the intermediate position (see "Operating the Retractable Shaft" and Fig. 2).
4. Lift both ends of the intermediate fabric/roller assembly into place and align between the rear/upper brackets.
5. Installer #1 fully extends coupler shaft of previously installed roller by rotating the metal ring clockwise about 180° when viewing the face of the coupler assembly (see "Operating the Retractable Shaft" and Fig. 2), until the shaft extends fully into the receiver of the fabric/roller assembly being installed.
6. Installer #2 extends the coupler shaft of the fabric/roller assembly being installed to the intermediate position by rotating the ring clockwise about 120° (see "Operating the Retractable Shaft" and Fig. 2) so the end of the shaft is flush with the outside edge of the bearing.
7. Operate the shade to ensure proper fabric tracking.
8. Lower the unit (all shades will operate simultaneously) to lower limit.
9. If needed, the fabric panel heights can be adjusted so that the bottom edges of the fabric panels are aligned. On large units, this procedure should be done on only one panel at a time to minimize the amount of fabric weight that must be supported during the adjustment procedure. (See Section 6, "Fabric/Roller Assembly Alignment") for instructions.
10. Repeat steps above under "Second Fabric/Roller Assembly" for additional intermediate panels.

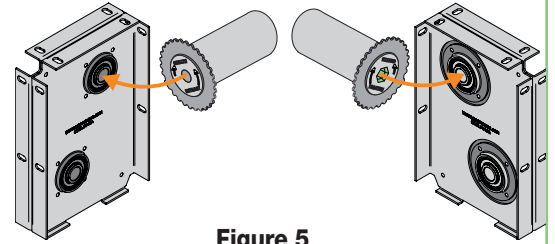

Figure 5

Section 2.5 - Final (Idler-end) Fabric/Roller Assembly (Fig. 6)

1. If desired, the proper location of the next bracket assembly can be verified. Otherwise, proceed to Step 2.
 2. Install idler-end bracket/endcap assembly.
 3. Retract coupler shaft of previously installed roller to the intermediate position (see "Operating the Retractable Shaft" and Fig. 2). The end of the coupler shaft should be flush with the outside edge of the bearing.
 4. Lift both ends of the idler-end fabric/roller assembly into place and align between the brackets/endcaps.
 5. Installer #1 places the idler-end sliding shaft onto the idler-end bracket (Fig. 6). Lock shaft in place by placing retaining clip on shaft.
 6. Installer #2 fully extends coupler shaft of previously installed roller by rotating the metal ring clockwise about 1/2 of a turn when viewing the face of the coupler assembly (see "Operating the Retractable Shaft" and Fig. 2), until the shaft extends fully into the receiver of the idler-end fabric/roller assembly.
- ⚠ Caution:** Ensure shaft is locked in place with retaining clip on shaft.
7. Operate the unit to ensure proper fabric tracking.
 8. Lower the unit (all shades will operate simultaneously) to lower limit.
 9. If needed, the fabric panel heights can be adjusted so that the bottom edges of the fabric panels are aligned. **On large units, this procedure should be done on only one panel at a time to minimize the amount of fabric weight that must be supported during the adjustment procedure.** (See Section 6, "Fabric/Roller Assembly Alignment")
 10. Repeat steps followed for rear/upper fabric/roller assemblies under First (Operator-end) Fabric/Roller Assembly, Second Fabric/Roller Assembly and Final (Idler-end) Fabric/Roller Assembly sections above for lower/front fabric/roller assemblies.

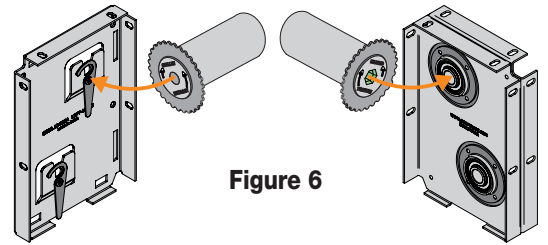

Figure 6

Section 3 - Fascia Attachment

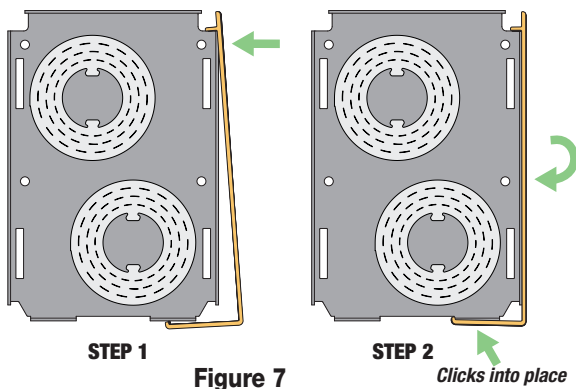
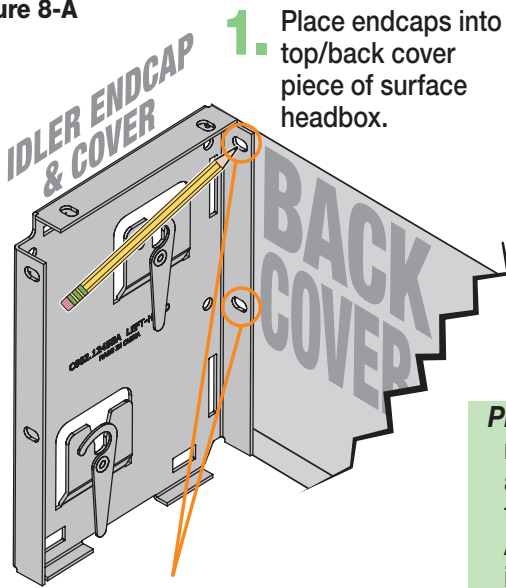

Figure 7

1. Place groove along top of fascia over endcaps, and snap into place (Fig. 7). Fascia is not fully seated until it clicks into place on both ends. Once in place, check for secure fit. If not secure, secure with appropriate fastener (not included).

Section 4 - Dual Roller Surface Headbox Installation

Figure 8-A



1. Place endcaps into top/back cover piece of surface headbox.

2. Using pre-drilled holes in endcaps, mark headbox for drilling.

Please Note: Installer must provide adequate clearance for removal of Roller Assembly during installation and maintenance.

Figure 8-B

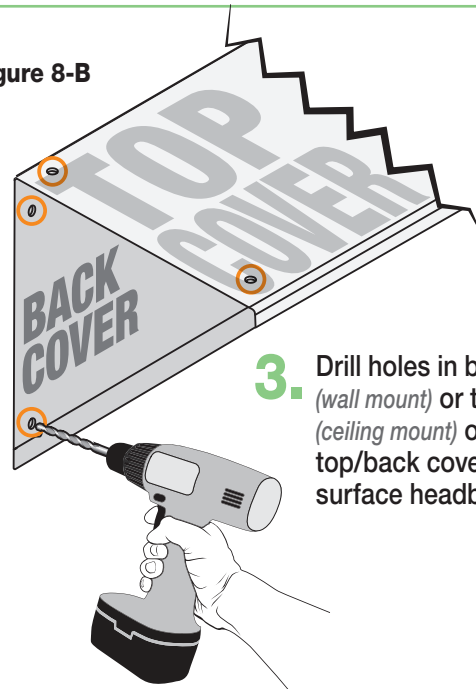

3. Drill holes in back (wall mount) or top (ceiling mount) of top/back cover of surface headbox.

Please Note: Headbox MUST BE mounted directly to ceiling or wall, or to a continuous blocking that has been secured to building structure.

Figure 8-C

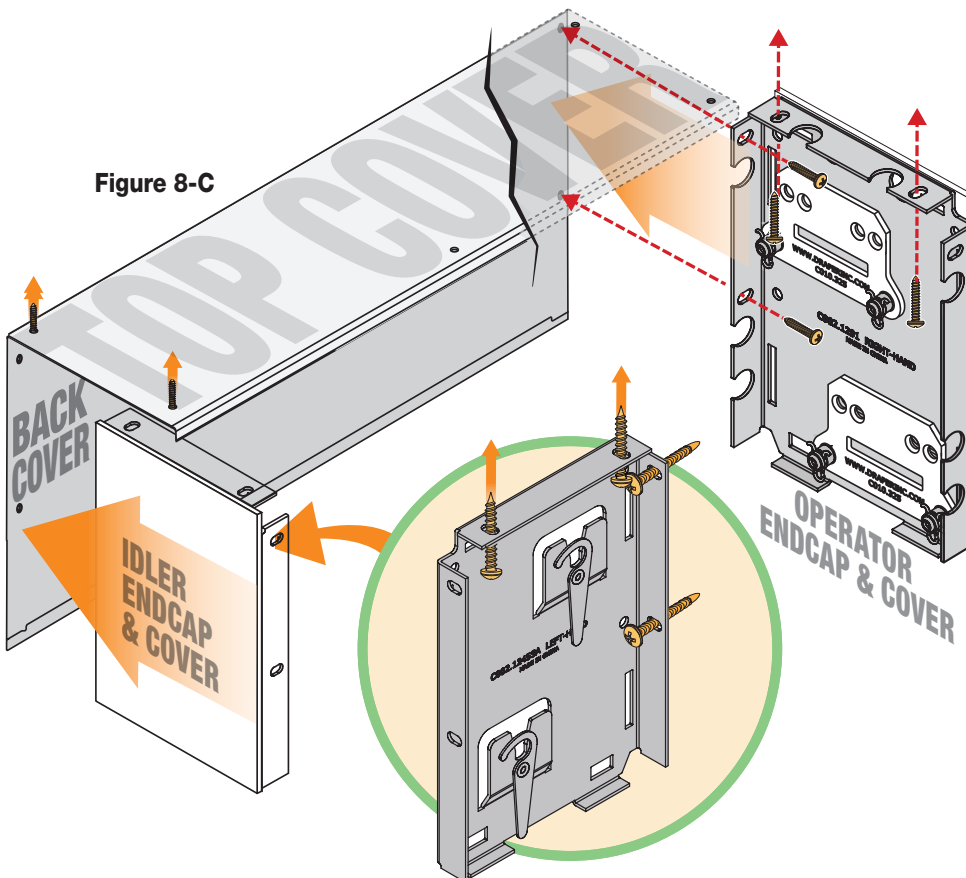

4. Attach endcaps and top/back cover piece to wall or ceiling, using mounting hardware appropriate for site conditions.

Please Note: A minimum of two (2) screws is required for each endcap.

Next, mount roller assemblies (Section 2).

Section 5 - Pocket Headbox Installation

PLEASE NOTE: Installer must provide adequate clearance for removal of Roller Assembly during installation and maintenance.

PLEASE NOTE: Headbox must be mounted directly to ceiling, or to a continuous blocking that is secured to building structure.

Figure 9-B

1. Lift headbox into mounting position.

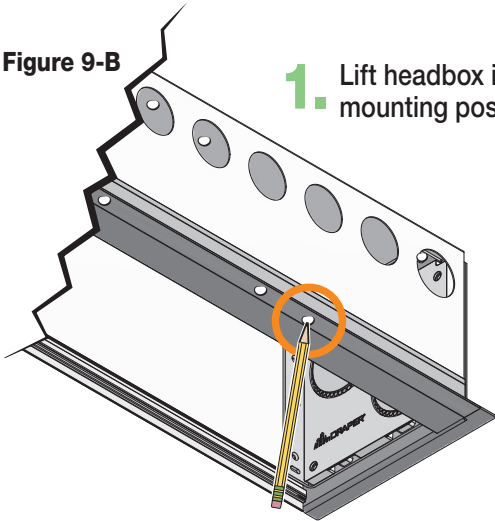

2. Mark location of optional pre-drilled pocket mounting holes and bracket mounting holes on top side of headbox on mounting surface.

Figure 9-A

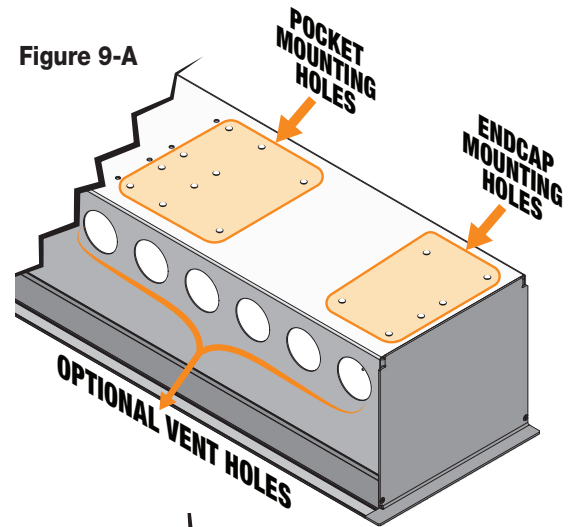
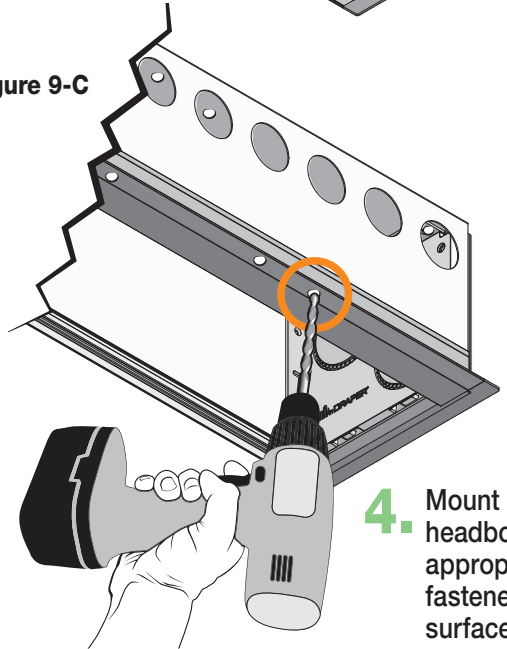

Figure 9-C

3. Drill small starter hole (if necessary) in mounting surface.



4. Mount pocket headbox using appropriate fasteners for surface.

Figure 9-D

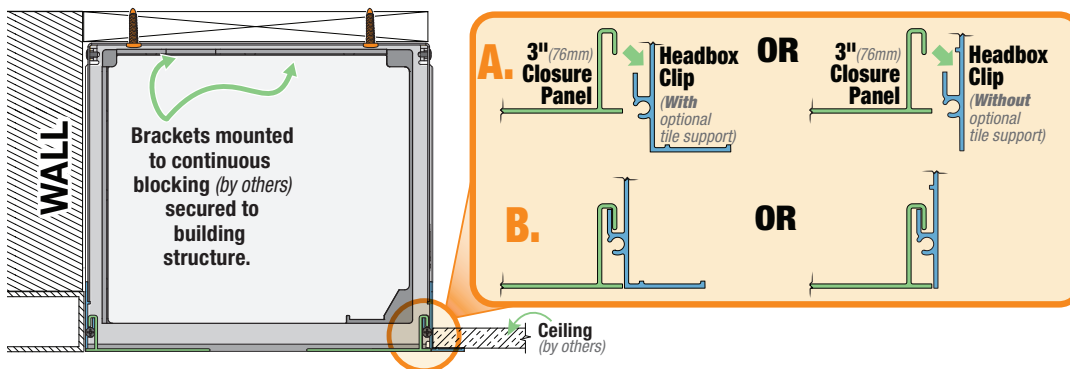

5. Mount endcaps using appropriate fasteners for surface (Section 1).

6. Mount pocket closure. (Fig. 9-D).

Section 6 - Fabric/Roller Assembly Alignment (Steps are shown for right-hand operators)

Please note: If needed, the fabric panel heights can be adjusted so that the bottom edges of the fabric panels are aligned. On large units, this procedure should be done on only one panel at a time to minimize the amount of fabric weight that must be supported during the adjustment procedure. Install and adjust rear/upper panels before beginning on lower/front panels.

1. Unlock height adjuster mechanism (or coupler shaft receiver) located at the operator-end of fabric roller assembly being adjusted by rotating the metal ring approximately ¼ turn counterclockwise when viewing the face of the coupler assembly.

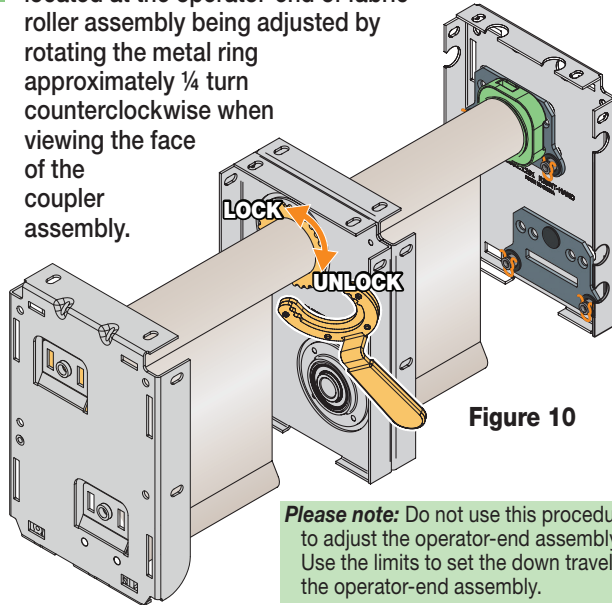

Figure 10

Please note: Do not use this procedure to adjust the operator-end assembly. Use the limits to set the down travel of the operator-end assembly.

2. Push the fabric/roller assembly approximately 3/16" (5mm) toward the operator-end of the unit. The fabric/roller assembly will move approximately 3/16" (5mm) toward the operator end.

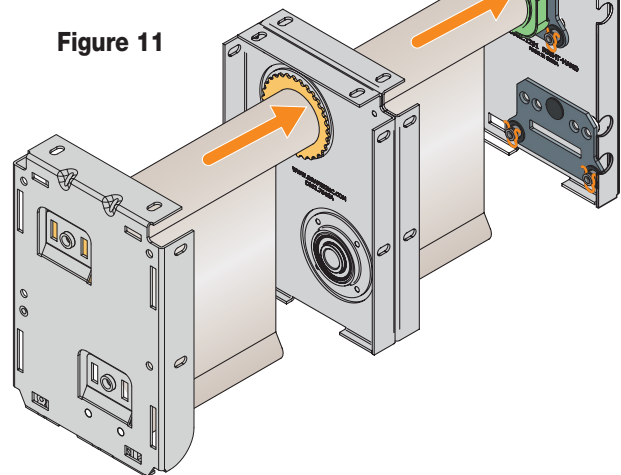

Figure 11

3. Rotate the fabric/roller assembly in either direction to raise or lower the fabric panel.

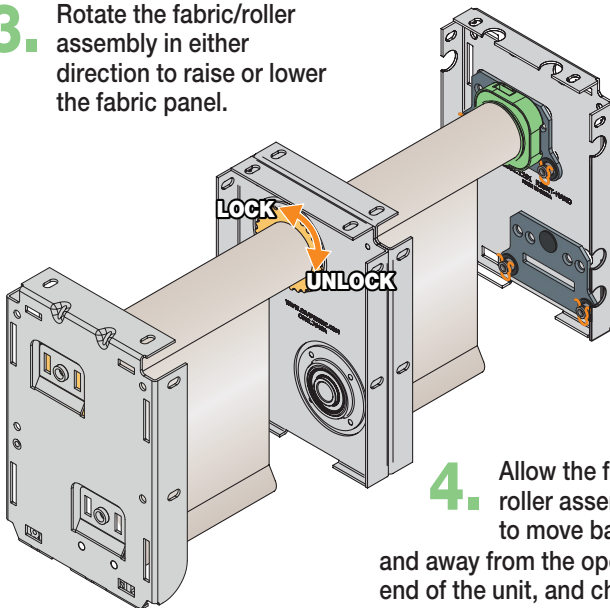

Figure 12

4. Allow the fabric/roller assembly to move back and away from the operator end of the unit, and check position of fabric panels.

5. Tighten the locking ring by firmly rotating it approximately ¼ turn clockwise (reverse of step 1).

6. Operate the unit to check for proper fabric position, tracking, etc.

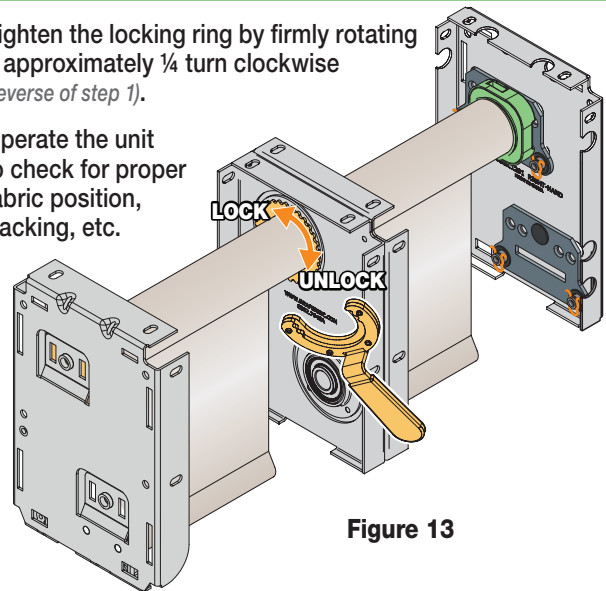

Figure 13

Caution: Ensure the locking ring on the idler-end coupler assembly is fully tightened following height adjustment. Wear a heavy glove to grip the locking ring. Tighten the locking ring until it is fully locked and will not rotate any further. Ensure that it will not loosen. If it cannot be tightened by hand, use a flat screwdriver or other tool to assist.

7. Install next panel.

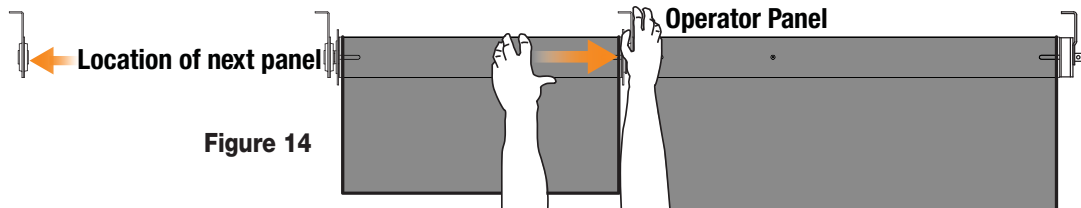

Figure 14

Section 7 - Limit Switch Adjustments

Section 7.1 - Standard and Quiet Motors (All procedures shown are for Standard Roll. Invert orientation for Reverse Roll)**Push Button Limits**

1. Fully depress both limit switch push buttons, then operate wall switch to make sure system works properly.
2. Raise shade to desired “up” stop position.
3. Set upper limit by depressing proper (*back*) push button.
4. Lower shade to desired “down” stop position.
5. Set lower limit by depressing proper (*front*) push button.

Screw-Type Limits

1. Determine which direction of fabric travel corresponds with arrows on motor.
2. Operate shade to desired “down” stop position. Set limit by turning proper socket toward “+” to lower limit, and “-” to raise it.
3. Operate shade to desired “up” stopping position. Set limit by turning proper screw toward “-” to raise limit, and “+” to lower it.

⚠ Caution:

- Be sure all switches are in “off” position before adjusting limit switches.
- Be prepared to shut off manually while testing.
- Shade may be damaged by running shade fabric down too far to expose roller.
- If using a group control system, each limit switch must be set prior to connecting to system.
- Motor must be installed so limit switches are pointed down.

PUSH BUTTON LIMITS

Standard right-hand motor configuration shown

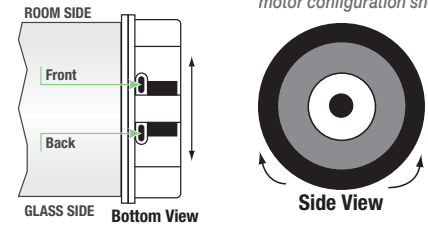
**SCREW-TYPE LIMITS**

Standard right-hand motor configuration shown

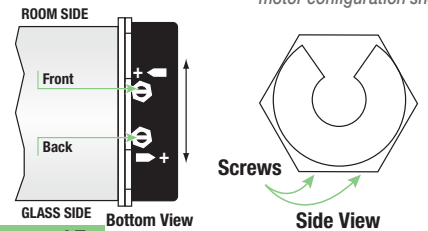
**Figure 15****Section 7.2 - Limit Adjustments: RS485 Motors**

For limit setting instructions on these motors, see instructions packaged with the RS485 Address/Limit Setting Tool (part# C156.241).

Section 7.3 - Limit Switch Adjustments: RTS Motors

For limit setting instructions on these motors, see Radio Frequency Remote Control Programming Instructions (FS_MO_RFRC_ProgInst).

Section 7.4 - Limit Switch Adjustments: IntelliFlex I/O Motors

For limit setting instructions on these motors, see instructions packaged with the Motor Limit Setting Tool (part# C202.030).

Section 8 - Electrical Connections

Shade operates on 110-120V, 60 Hz. current. Shade is shipped with internal wiring complete and control switch(es) fully boxed, and standardly supplied with a 6' (1.8 m) cable lead. Longer lead can be substituted by removing two screws in motor end of roller, removing lead, plugging new lead in, and replacing screws. Wire to connect shade to switch(es) and switch(es) to power supply should be furnished by installer.

Connections should be made in accordance with attached wiring diagram, and wiring should comply with national and local electrical codes. DO NOT wire motors in parallel without written permission from Draper®.

All operating switches should be “off” before power is connected.

Please Note: For low-voltage wiring requirements, Draper recommends consulting with a professional low-voltage electrical contractor. It is very important that shielded and stranded CAT 5 cable be used to prevent any electrical interference.

Please Note: A Draper Motor Test Cable (Part# 503109) and M12 Pigtail (Part# C107.089.60) are available for temporary power for testing and limit setting.

⚠ IMPORTANT: To reduce the risk of electric shock, equipment that features a grounding type attachment plug has a third (*grounding*) pin on the attachment plug. This plug will **ONLY** fit into a grounding type outlet. If the plug does not fit into the outlet, a qualified electrician must install the proper outlet. Do not change the plug in any way. Do not use an extension cord. If the power supply cord is too short, a qualified electrician must install an outlet near the drapery operator.

Section 8 - Electrical Connections (Continued)

Controls & System Overview

Sonesse® 120VAC Motors

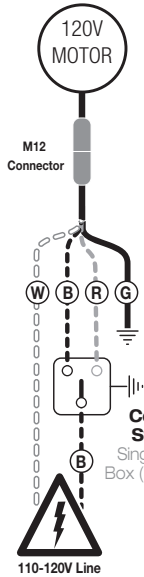

NOTE: Test shade operation
If shade direction does not correspond with the switch orientation, turn power off. Consult a licensed electrician to switch the red and black wires from the motor to the switch.

Do not wire motors in parallel without written permission from Draper®.

Sonesse® is a registered trademark of Somfy® Systems, Inc.

Dashed Wiring by Electrician

Controls & System Overview

Sonesse® RTS 120VAC Motors

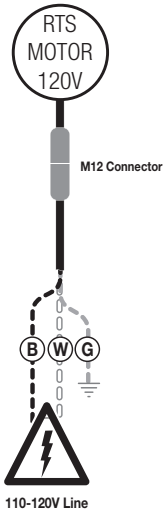

Telis 1 RF Remote

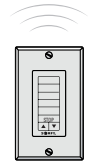

DecoFlex Wire Free Keypad

Dashed Wiring by Electrician

M12 Connector for 4-Wire Motors

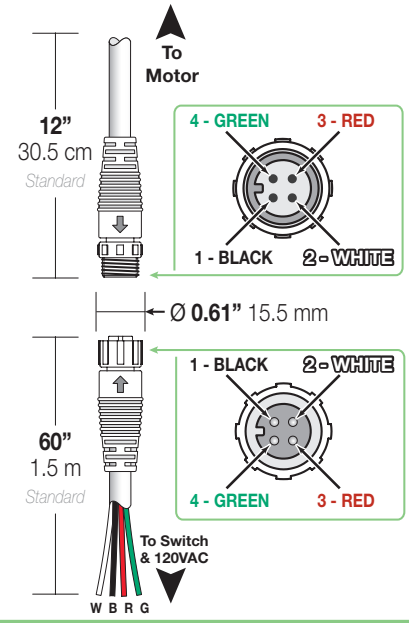

M12 Connector for 3-Wire Motors

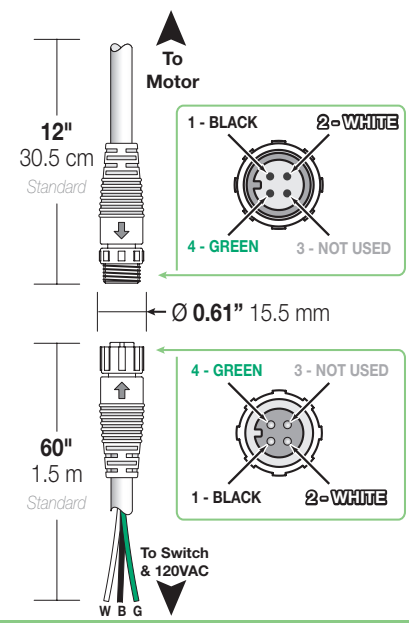

Controls & System Overview

Sonesse® 485 120VAC Motors

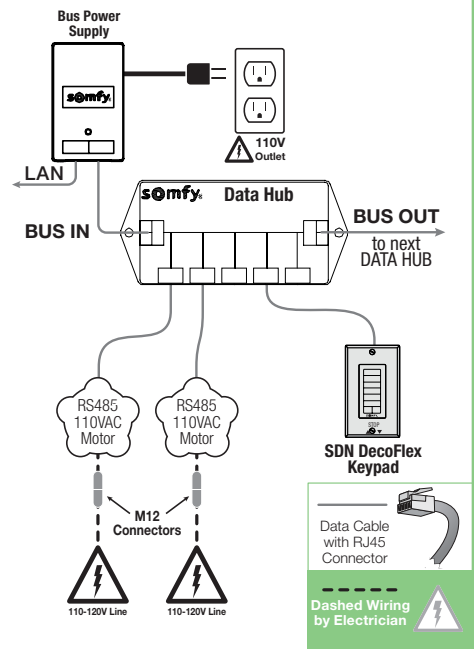

Data Cable with RJ45 Connector

Dashed Wiring by Electrician

Data Cable Pin-Out - RJ45 Connector

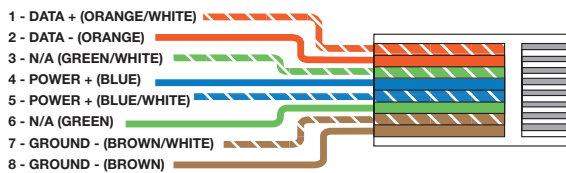

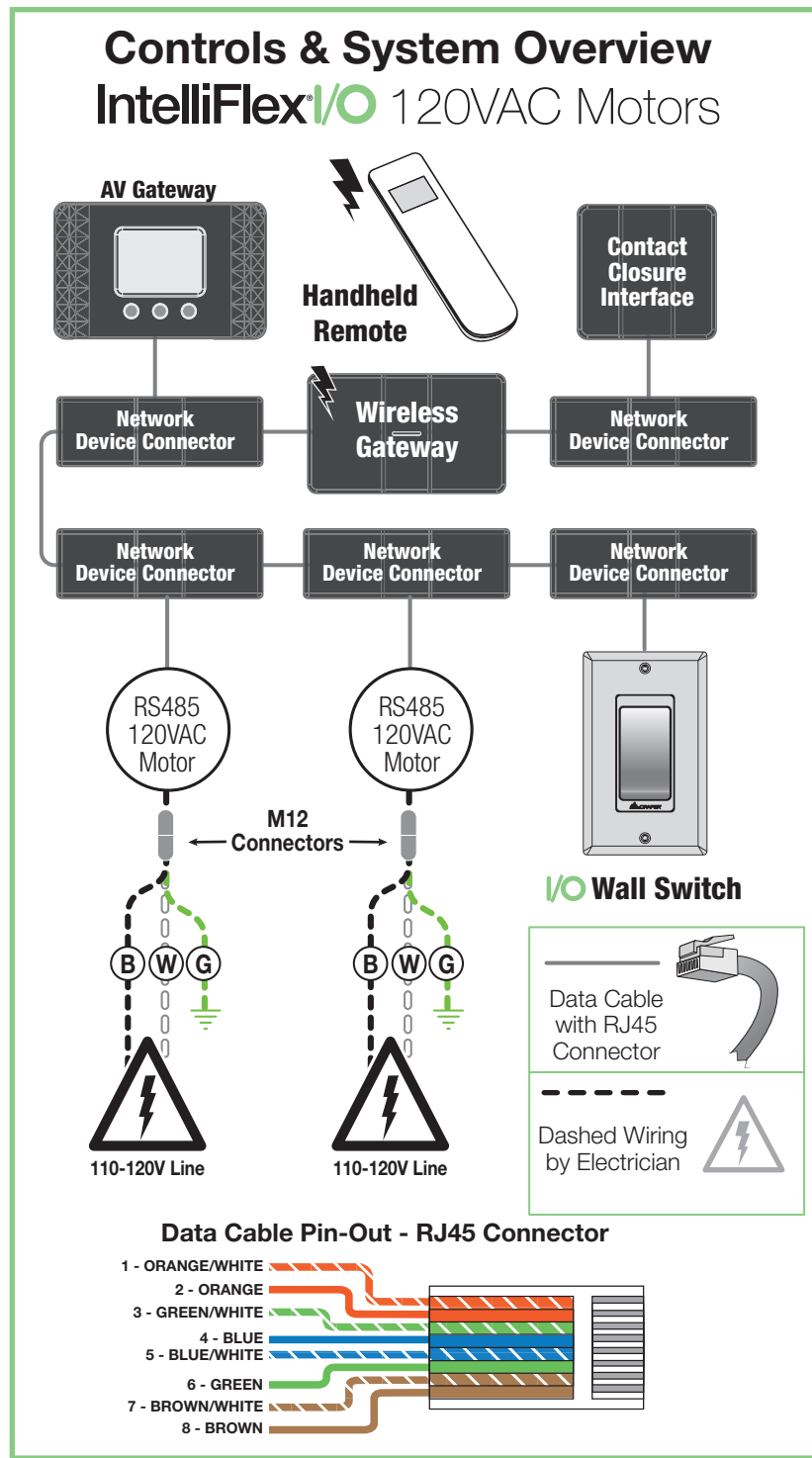

Section 9 - Dimensions

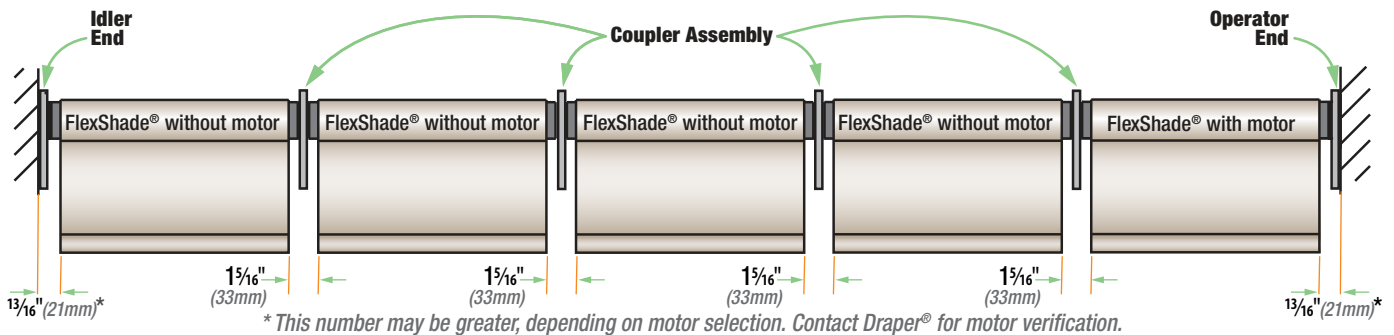

Section 9 - Dimensions (continued)

Endcap & Fascia Dimensions

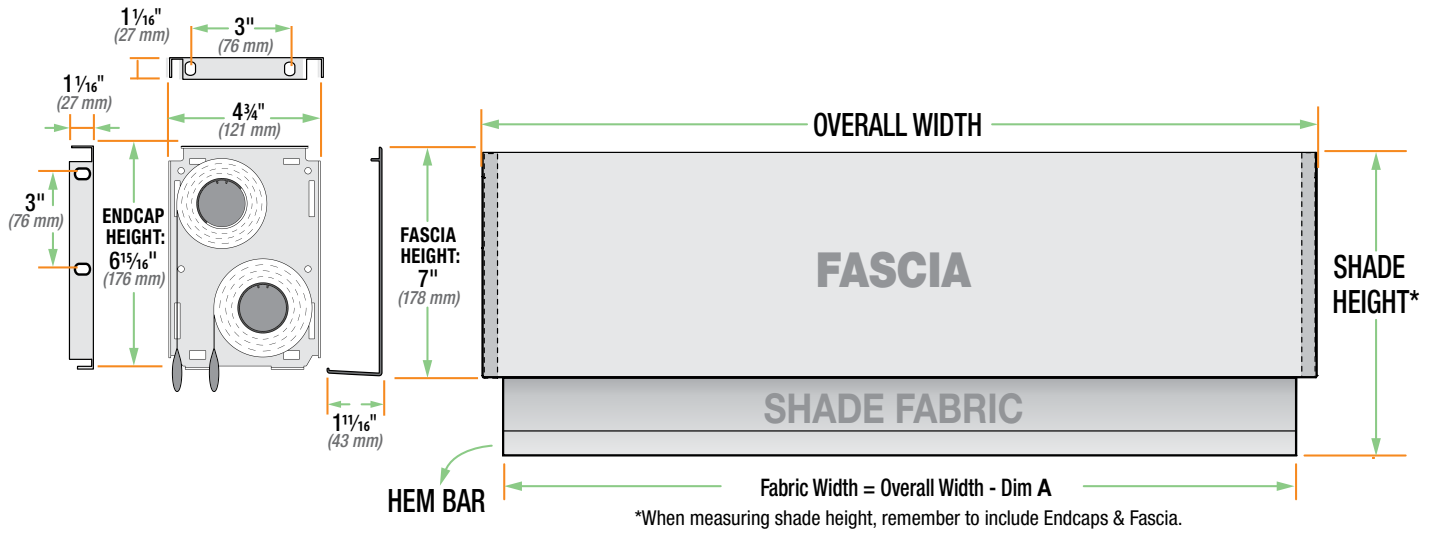

Dual Roller Surface Headbox Dimensions

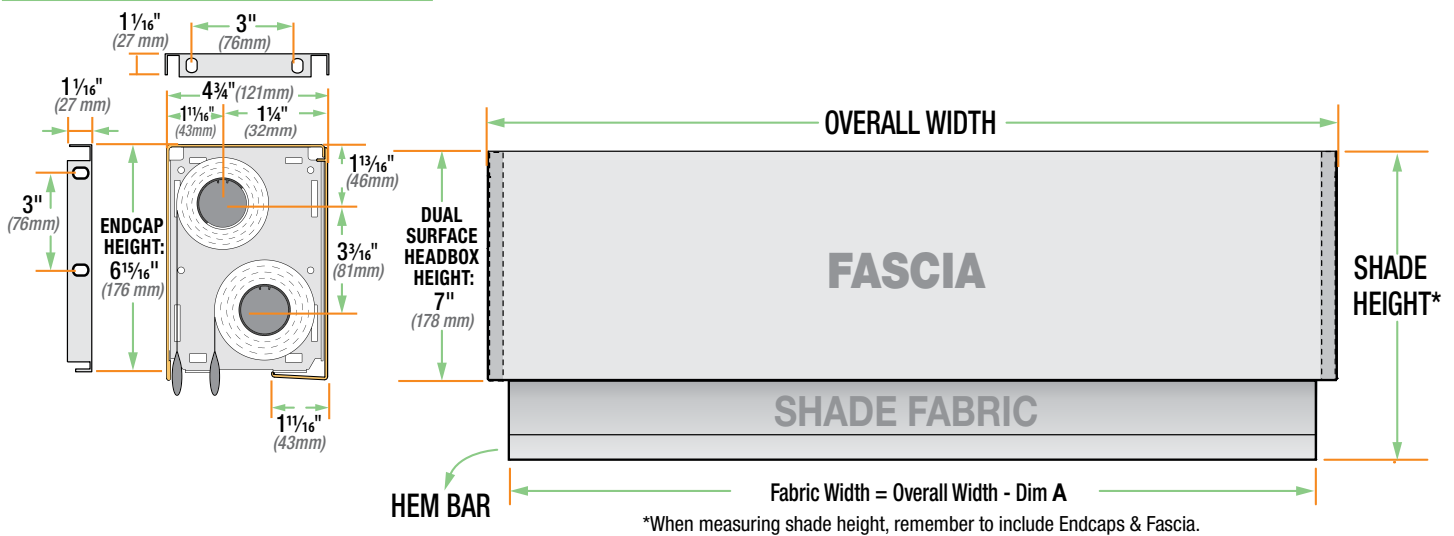

Dual Roller Pocket Headbox Dimensions

Standard Dual Roller Pocket Headbox Dimensions

