

Dual Roller Motorized FlexShade®

Standard, large, and extra large hardware

This document is to be used with the **Motorized FlexShade® Submittal**.

On the diagram below, please provide the following information: (If specifying a Coupled FlexShade, also indicate desired locations for couplers.)

Rear Roller Fabric: _____ Color / Number: _____ Openness Factor: _____
*Please see the Shade Fabric Reference Guide on the Draper® website for fabric colors and specifications.
Front Roller Fabric: _____ Color / Number: _____ Openness Factor: _____
*Please see the Shade Fabric Reference Guide on the Draper® website for fabric colors and specifications.

Please Note: Shade fabrics can be placed anywhere in the headbox. Fabric or screen can be no closer than 13/16" (21mm) to either end of the headbox.

Select Hardware Finish

- Clear Anodized (standard)
- Black
- Ivory
- White
- Bronze
- Custom (Contact Draper®)

Select Dual Roller Hardware (Hardware Dimensions available starting on page 2.)

- Dual Endcaps Only
- Dual Endcaps with Fascia

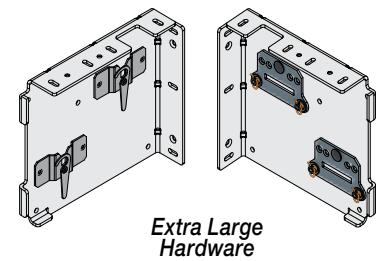
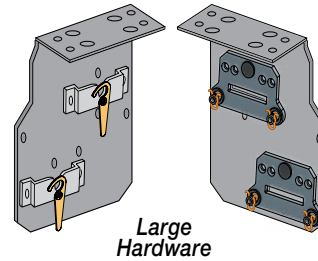
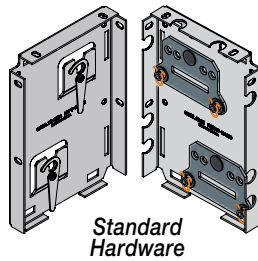

Select Coupler

- Coupler Quantity: _____

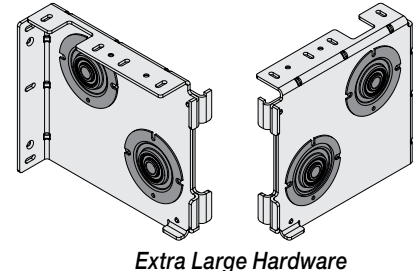
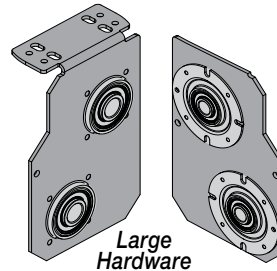
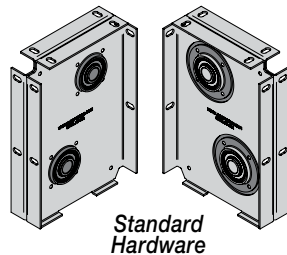

Select Headbox

- Dual Headbox
 - Pocket Headbox (standard or large; sizes chosen by Draper)
 - Dual Pocket Headbox Tile Flange:
 - Front (standard)
 - Left
 - None
 - Dual Pocket Headbox Ventilation Holes:
 - Yes
 - No (standard)
 - Pre-Drilled Shade Endcap Mounting Holes:
 - Yes (standard)
 - No
 - Pre-Drilled Pocket Headbox Mounting Holes:
 - Yes
 - No (standard)
 - Back
 - Right
- Ceiling / Wall (Surface Headbox)
- Custom Headbox

Select Light Block Option

- "L", "U", or "H" Channels for Light Gap Reduction
 - "L" Angle
 - "H" Channel
 - "U" Channel
 - Channel Liners

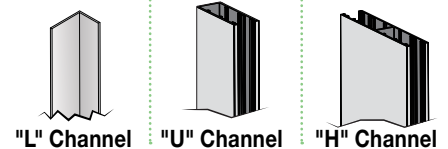

PROJECT: _____

ARCHITECT: _____

CONTRACTOR: _____

SUPPLIER: _____

DATE: _____ **REVISED:** _____



Standard Hardware Specifications

PATENT INFORMATION: Available at <http://www.draperinc.com/legal/patents>

DOWNLOADABLE 3-PART SPECIFICATIONS: Available at www.draperinc.com

Please note: Dimensions of rollers, operators, and hardware at manufacturer's discretion.

DUAL ROLLER ENDCAPS

Endcaps for surface or recessed mounting of dual roller window shades.

1028 STEEL STAMPING: Complete with adapter roller bracket. Installs to wall, ceiling, or jamb. Accepts fascia.

SIZE: 4 3/4" (121 mm) deep x 7" (178 mm) high x length required by window opening.

DUAL ROLLER FASCIA

Endcaps with fascia designed for surface mounting of dual roller window shades.

ENDCAPS: 1028 steel stamping. Complete with adapter roller bracket. Installs to wall, ceiling, or jamb.

FASCIA: L-shaped cover of extruded aluminum, .060" (1.524 mm) wall. Assembly snaps onto endcaps without exposed fasteners.

FINISH: Clear Anodized (standard), black, white, ivory, or bronze powder coat.

SIZE: 4 3/4" (121 mm) deep x 7" (178 mm) high x length required by window opening.

DUAL ROLLER WITH POCKET HEADBOX

Pocket and endcaps designed for recessed ceiling installation of dual roller window shades.

ENDCAPS: 1028 steel stamping. Complete with adapter roller bracket.

HEADBOX: 18-gauge steel pocket, for mounting directly to ceiling, wall, or continuous blocking that is secured to building structure. Optional pre-drilled mounting holes and pre-drilled ventilation holes.

FINISH: White Inside/Grey Outside with white ceiling flange or Grey Inside/White Outside with white ceiling tile flange. Front Tile Flange. Optional left and right Tile Flanges available.

SIZE: 5 3/4" (146 mm) wide by 7 3/4" (197 mm) high.

DUAL ROLLER WITH CEILING/WALL HEADBOX

Fascia, L-shaped top/back, and endcaps designed for wall or ceiling installation of dual roller window shades.

ENDCAPS: 1028 steel stamping. Complete with adapter roller bracket.

FASCIA: L-shaped cover of extruded aluminum, .060" (1.524 mm) wall. Assembly snaps onto endcaps without exposed fasteners.

SIZE: 4 3/4" (121 mm) deep x 7" (178 mm) high x length required by window opening.

FINISH: Clear Anodized (standard), black, white, ivory, or bronze powder coat.

LIGHT GAP REDUCTION HARDWARE: Extruded Aluminum. Accepts edges of fabric, prevents light gaps. Interior of channel provides for use of flat head screws.

"L" ANGLE: 3/4" x 1" x 12'3" (1.9x2.5x373cm); 1" x 2 3/4" x 16' (2.5x7x488cm) or cut to length.

"U" CHANNEL: 1" x 2 1/2" x 16' (2.5x6.4x488cm) or cut to length.

"H" CHANNEL: 1" x 5" x 16' (2.5x12.7x488cm) or cut to length.

COUPLER ASSEMBLY: Zinc plated steel Coupler Shafts are retractable into coupler assembly for ease of installation and to lock units in place. Zinc plated steel coupler brackets have spherical OD bearings allowing for misalignment of the mounting brackets of up to 1.25-degrees. One motor to drive additional shade rollers.

ROLLER: Fabricated from extruded aluminum or steel. Wall thickness and material selected by manufacturer to accommodate shade size. Roller idler assembly of molded nylon and zinc-plated steel pin. Sliding pin provides easy installation and removal of roller. Fabric connected to the roller tube with LSE (low surface energy) double sided adhesive specifically developed to attach coated textiles to metal. Adhesive attachment eliminates horizontal impressions in fabric.

SHADE SLAT:

CLOSED POCKET ELLIPTICAL SLAT: 1" (25 mm) aluminum elliptical slat inside of a 1 5/8" (41 mm) pocket with heat sealed ends.

OPEN POCKET ELLIPTICAL SLAT: 1" (25 mm) aluminum elliptical slat with plastic ends inside of a 1 5/8" (41 mm) pocket.

SMALL FLAT EXPOSED HEM BAR: 7/8" x 3/16" (22 mm x 8 mm) and Large 1 1/2" x 5/16" (38 mm x 8 mm) aluminum rectangular hem bar with plastic endcaps.

LARGE FLAT EXPOSED HEM BAR: 1 1/2" x 3/16" (38 mm x 8 mm) aluminum rectangular hem bar with plastic endcaps.

ROUND EXPOSED HEM BAR: Small 3/8" (16 mm) and Large 1/2" (21 mm) aluminum with plastic endcaps.

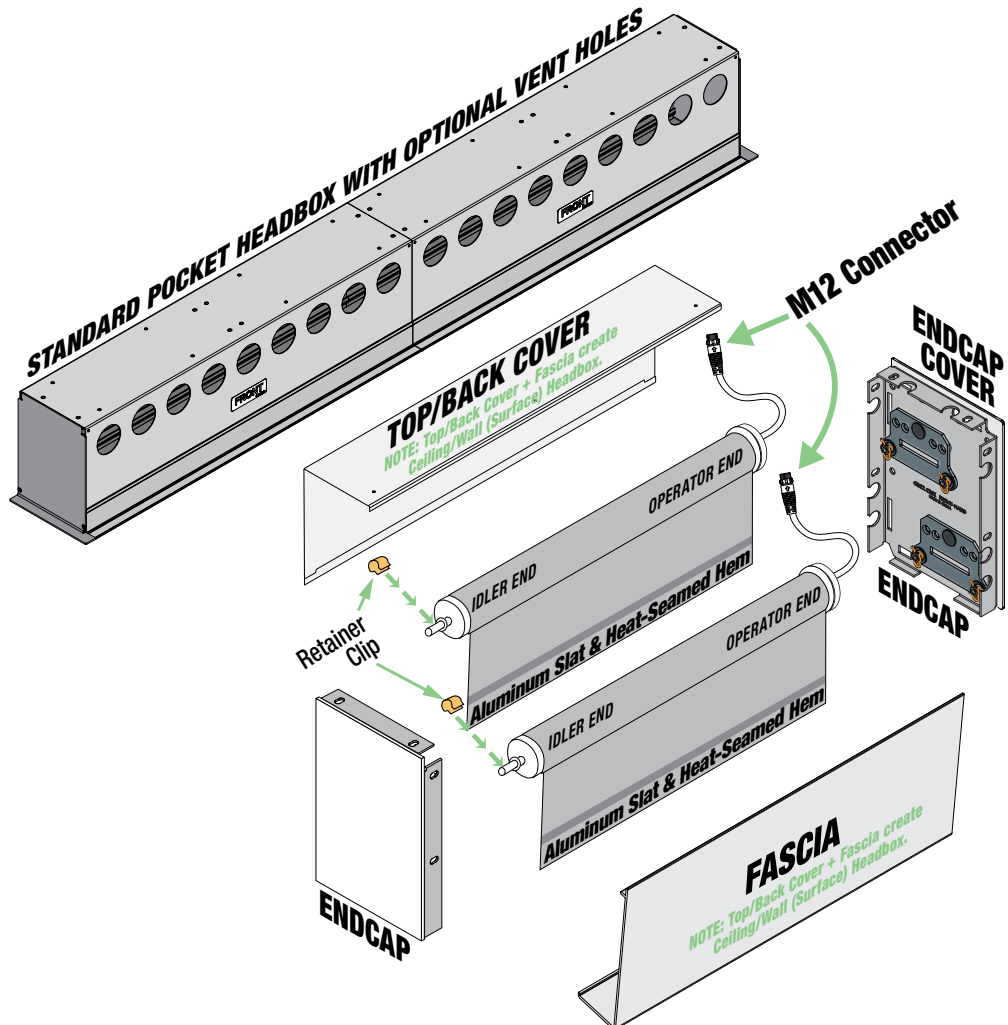

Standard Hardware Dimensions

Endcap & Fascia Dimensions

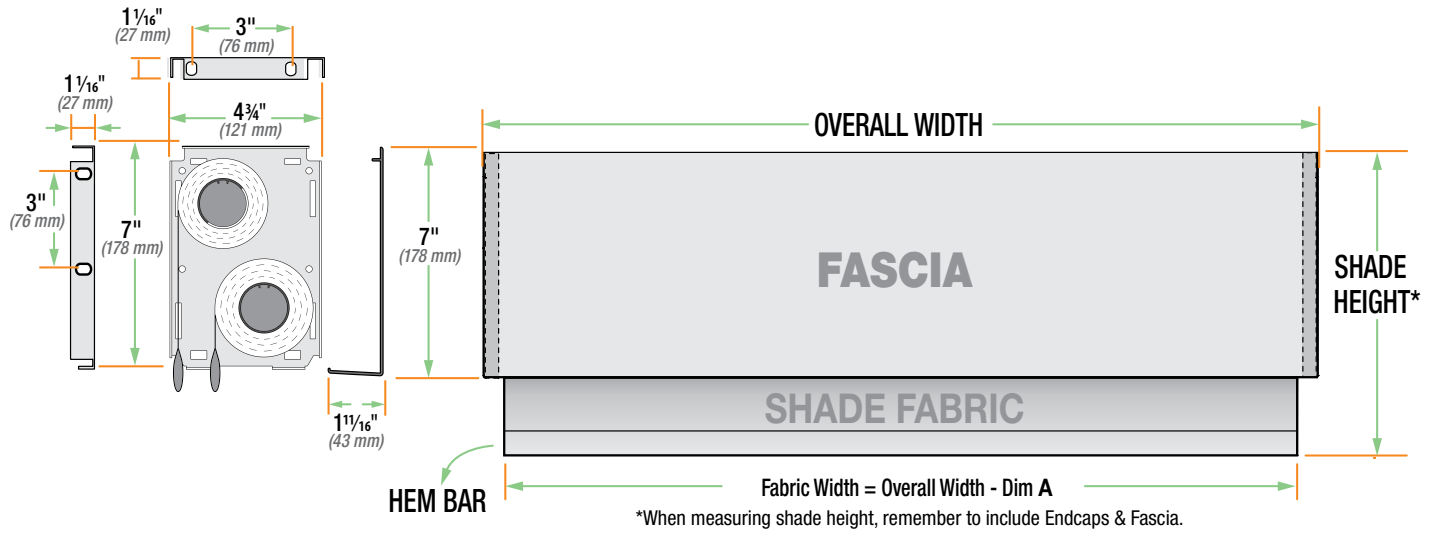

Dual Roller Surface Headbox Dimensions

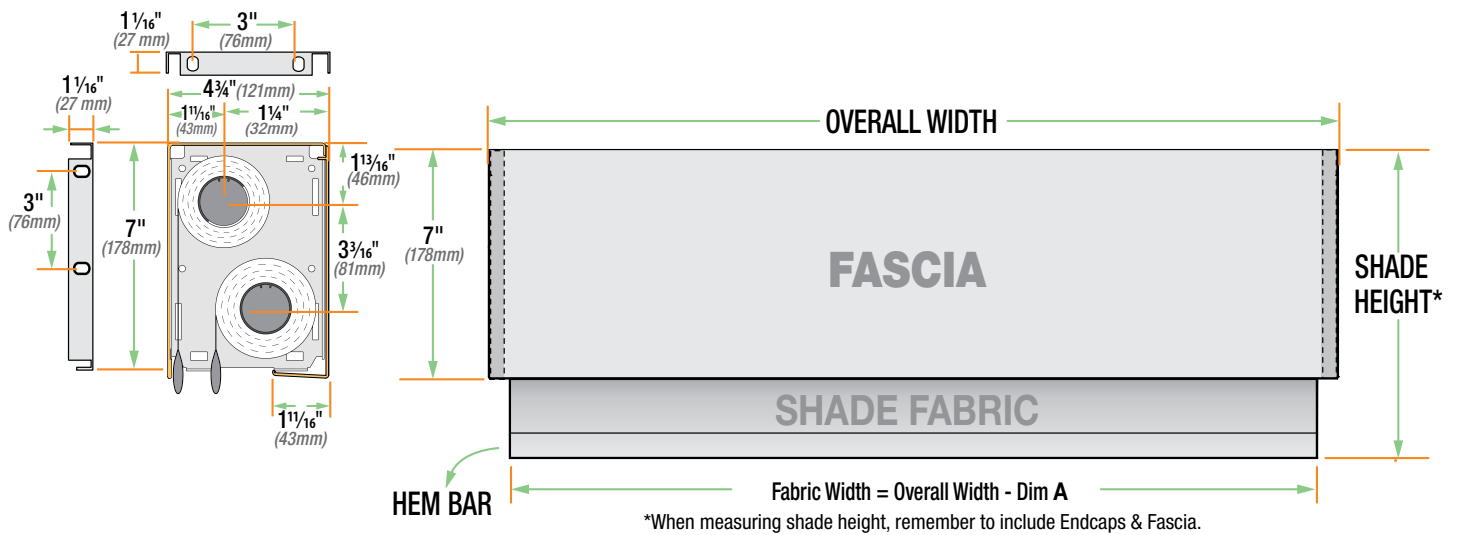

Dual Roller Pocket Headbox Dimensions

Standard Dual Roller Pocket Headbox Dimensions

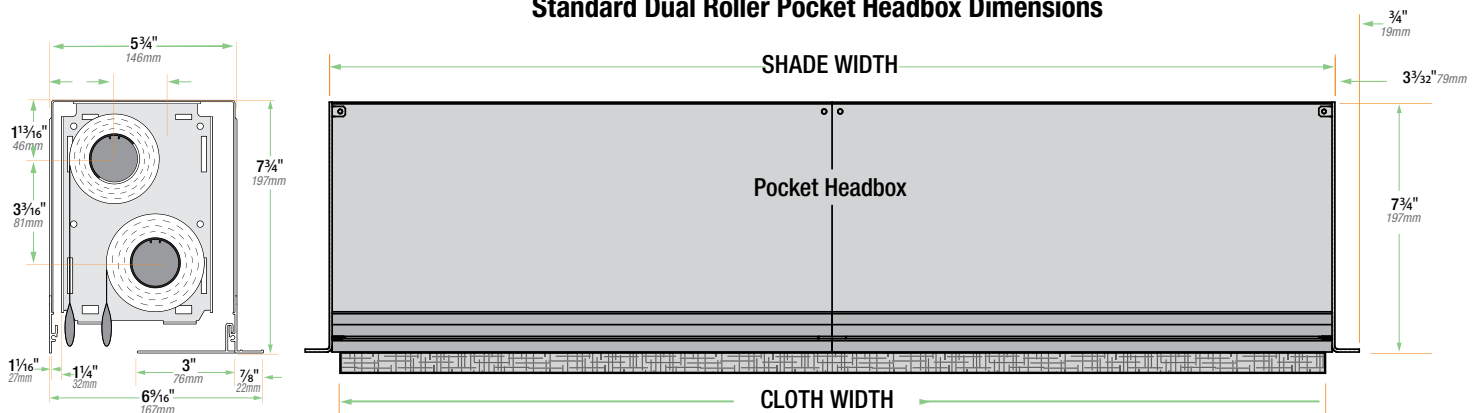

Large Hardware Specifications

PATENT INFORMATION: Available at <http://www.draperinc.com/legal/patents>

DOWNLOADABLE 3-PART SPECIFICATIONS: Available at www.draperinc.com

Please note: Dimensions of rollers, operators, and hardware at manufacturer's discretion.

DUAL ROLLER WITH POCKET HEADBOX

Pocket and endcaps designed for recessed ceiling installation of dual roller window shades.

ENDCAPS: 1028 steel stamping. Complete with adapter roller bracket.

HEADBOX: 18-gauge steel pocket, for mounting directly to ceiling, wall, or continuous blocking that is secured to building structure. Optional pre-drilled mounting holes and pre-drilled ventilation holes.

FINISH: White Inside/Grey Outside with white ceiling flange or Grey Inside/White Outside with white ceiling tile flange. Front Tile Flange. Optional left and right Tile Flanges available.

SIZE: 6 1/2" (165 mm) wide by 8 1/2" (216 mm) high.

DUAL ROLLER WITH CEILING/WALL HEADBOX

Fascia, L-shaped top/back, and endcaps designed for wall or ceiling installation of dual roller window shades.

ENDCAPS: 1028 steel stamping. Complete with adapter roller bracket.

FASCIA: L-shaped cover of extruded aluminum, .060" (1.524 mm) wall. Assembly snaps onto endcaps without exposed fasteners.

SIZE: 6 1/2" (165 mm) wide by 8 1/2" (216 mm) high.

FINISH: Clear Anodized (standard), black, white, ivory, or bronze powder coat.

LIGHT GAP REDUCTION HARDWARE: Extruded Aluminum. Accepts edges of fabric, prevents light gaps. Interior of channel provides for use of flat head screws.

"L" ANGLE: 3/4" x 1" x 12'3" (1.9x2.5x373cm); 1" x 2 3/4" x 16' (2.5x7x488cm) or cut to length.

"U" CHANNEL: 1" x 2 1/2" x 16' (2.5x6.4x488cm) or cut to length.

"H" CHANNEL: 1" x 5" x 16' (2.5x12.7x488cm) or cut to length.

COUPLER ASSEMBLY: Zinc plated steel Coupler Shafts are retractable into coupler assembly for ease of installation and to lock units in place. Zinc plated steel coupler brackets have spherical OD bearings allowing for misalignment of the mounting brackets of up to 1.25-degrees. One motor to drive additional shade rollers.

ROLLER: Fabricated from extruded aluminum or steel. Wall thickness and material selected by manufacturer to accommodate shade size. Roller idler assembly of molded nylon and zinc-plated steel pin. Sliding pin for easy installation and removal of roller. Fabric connected to the roller tube with LSE (low surface energy) double sided adhesive specifically developed to attach coated textiles to metal. Adhesive attachment to eliminate horizontal impressions in fabric.

SHADE SLAT:

CLOSED POCKET ELLIPTICAL SLAT: 1" (25 mm) aluminum elliptical slat inside of a 1 3/8" (41 mm) pocket with heat sealed ends.

OPEN POCKET ELLIPTICAL SLAT: 1" (25mm) aluminum elliptical slat with plastic ends inside of a 1 3/8" (41 mm) pocket.

SMALL FLAT EXPOSED HEM BAR: 7/8" x 3/8" (22 mm x 8 mm) and Large 1 1/2" x 3/8" (38 mm x 8 mm) aluminum rectangular hem bar with plastic endcaps.

LARGE FLAT EXPOSED HEM BAR: 1 1/2" x 3/8" (38 mm x 8 mm) aluminum rectangular hem bar with plastic endcaps.

ROUND EXPOSED HEM BAR: Small 3/8" (16 mm) and Large 1/2" (21 mm) aluminum with plastic endcaps.

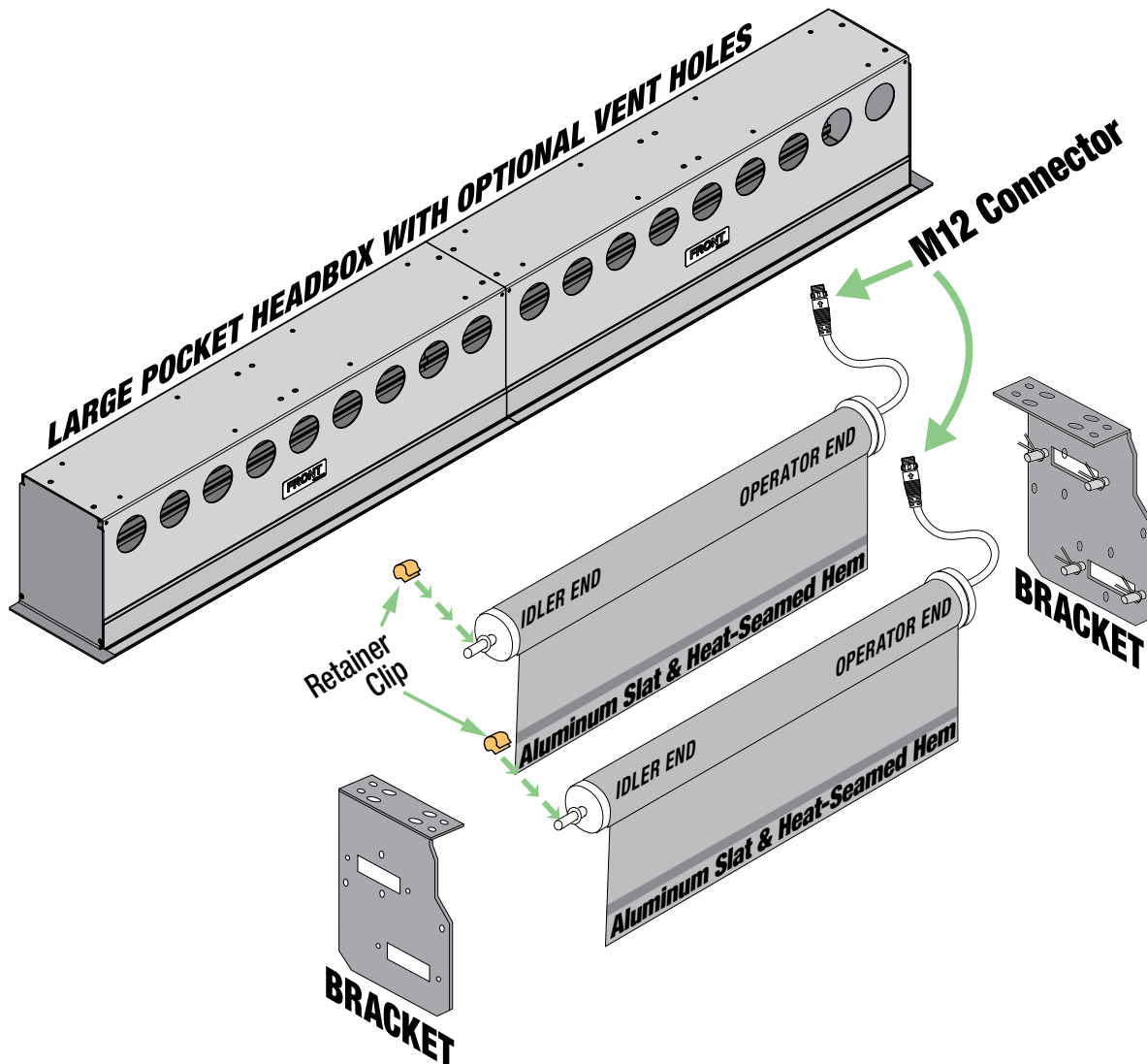

Large Hardware Dimensions

Large Dual Roller Pocket Headbox Dimensions

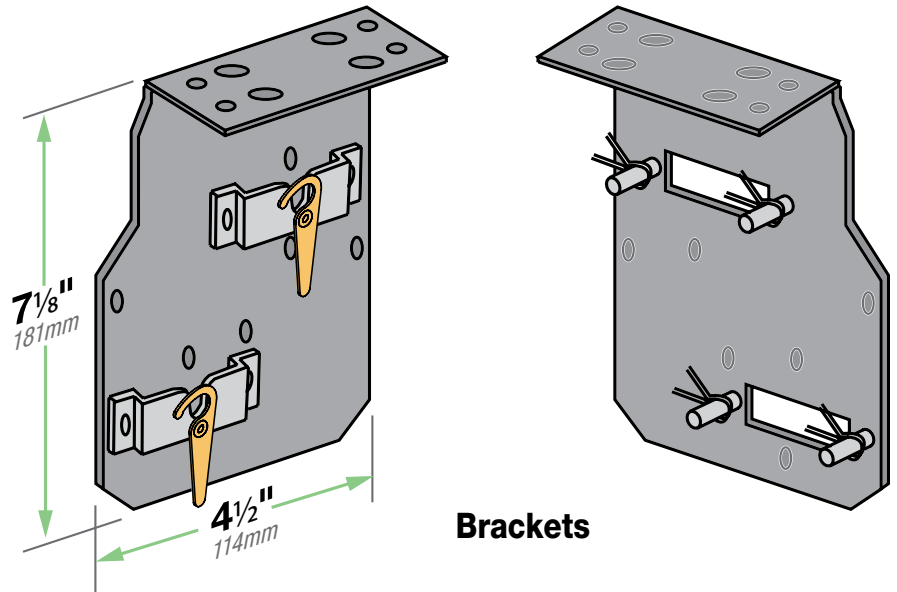
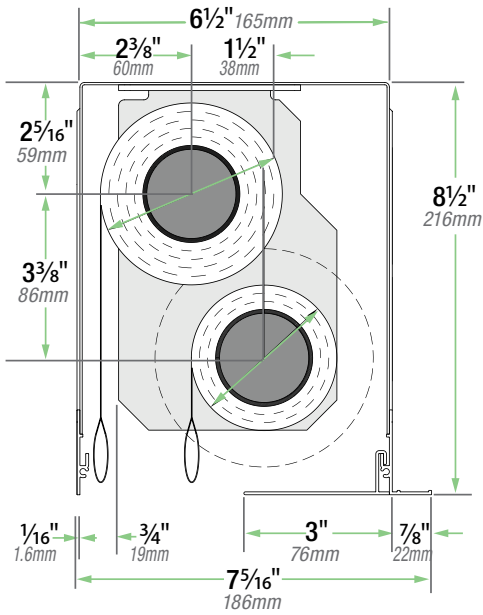
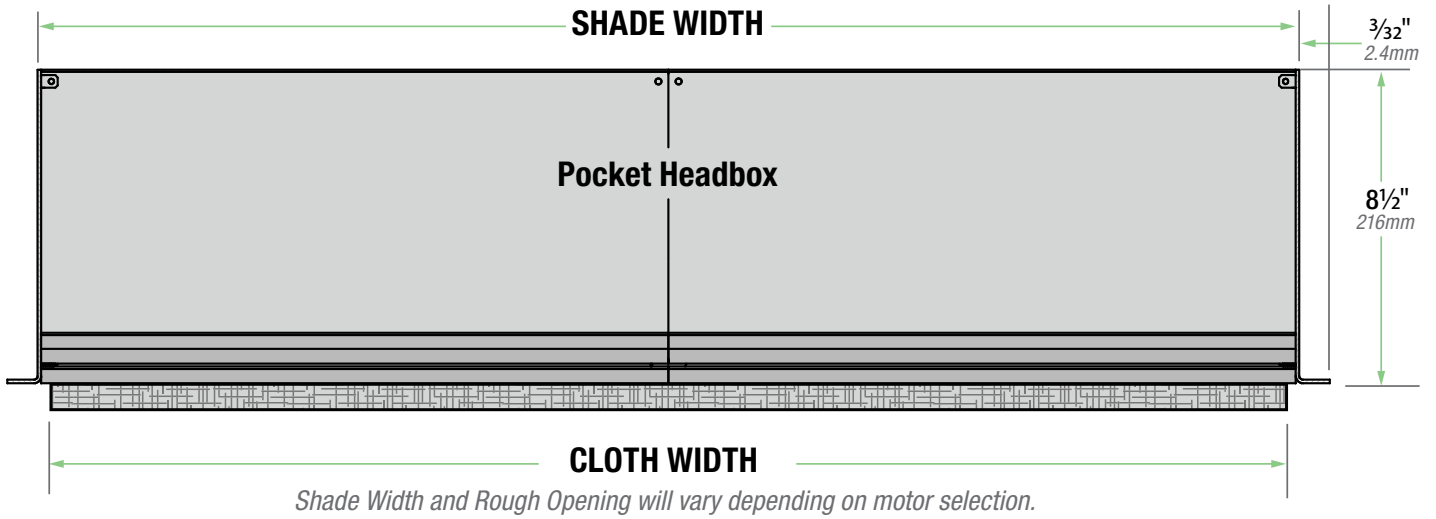

Extra Large Hardware Specifications

PATENT INFORMATION: Available at <http://www.draperinc.com/legal/patents>

DOWNLOADABLE 3-PART SPECIFICATIONS: Available at www.draperinc.com

Please note: Dimensions of rollers, operators, and hardware at manufacturer's discretion.

DUAL ROLLER FASCIA

Endcaps with fascia designed for surface mounting of dual roller window shades.

ENDCAPS: 1028 steel stamping. Complete with adapter roller bracket. Installs to wall, ceiling, or jamb.

FASCIA: L-shaped cover of extruded aluminum, .060" (1.524 mm) wall. Assembly snaps onto endcaps without exposed fasteners.

FINISH: Clear Anodized (standard), black, white, ivory, or bronze powder coat.

SIZE: 7 7/8" (200 mm) deep x 6 1/2" (178 mm) high x length required by window opening.

DUAL ROLLER WITH POCKET HEADBOX.

Pocket and endcaps designed for recessed ceiling installation of dual roller window shades.

ENDCAPS: 1028 steel stamping. Complete with adapter roller bracket.

HEADBOX: 18-gauge steel pocket, for mounting directly to ceiling, wall, or continuous blocking that is secured to building structure. Optional pre-drilled mounting holes and pre-drilled ventilation holes.

FINISH: White Inside/Grey Outside with white ceiling flange or Grey Inside/White Outside with white ceiling tile flange. Front Tile Flange. Optional left and right Tile Flanges available.

SIZE: 7 1/8" (202 mm) wide by 7" (178 mm) high.

CLOSURE PANEL: Aluminum, without exposed fasteners. 3" (76 mm) wide x length required for headbox.

DUAL ROLLER WITH CEILING/WALL HEADBOX

Fascia, L-shaped top/back, and endcaps designed for wall or ceiling installation of dual roller window shades.

ENDCAPS: 1028 steel stamping. Complete with adapter roller bracket.

FASCIA: L-shaped cover of extruded aluminum, .060" (1.524 mm) wall. Assembly snaps onto endcaps without exposed fasteners.

FINISH: Clear Anodized (standard), black, white, ivory, or bronze powder coat.

SIZE: 7 1/8" (202 mm) deep by 7" (178 mm) high x length required by window opening.

LIGHT GAP REDUCTION HARDWARE: Extruded Aluminum. Accepts edges of fabric, prevents light gaps. Interior of channel provides for use of flat head screws.

"L" ANGLE: 3/4" x 1" x 12'3" (1.9x2.5x373cm); 1" x 2 3/4" x 16' (2.5x7x488cm) or cut to length.

"U" CHANNEL: 1" x 2 1/2" x 16' (2.5x6.4x488cm) or cut to length.

"H" CHANNEL: 1" x 5" x 16' (2.5x12.7x488cm) or cut to length.

COUPLER ASSEMBLY: Zinc plated steel Coupler Shafts are retractable into coupler assembly for ease of installation and to lock units in place. Zinc plated steel coupler brackets have spherical OD bearings allowing for misalignment of the mounting brackets of up to 1.25-degrees. One motor to drive additional shade rollers.

ROLLER: Fabricated from extruded aluminum or steel. Wall thickness and material selected by manufacturer to accommodate shade size. Roller idler assembly of molded nylon and zinc-plated steel pin. Sliding pin for easy installation and removal of roller. Fabric connected to the roller tube with LSE (low surface energy) double sided adhesive specifically developed to attach coated textiles to metal. Adhesive attachment to eliminate horizontal impressions in fabric.

SHADE SLAT:

CLOSED POCKET ELLIPTICAL SLAT: 1" (25 mm) aluminum elliptical slat inside of a 1 1/8" (41 mm) pocket with heat sealed ends.

OPEN POCKET ELLIPTICAL SLAT: 1" (25mm) aluminum elliptical slat with plastic ends inside of a 1 1/8" (41 mm) pocket.

SMALL FLAT EXPOSED HEM BAR: 7/8" x 3/16" (22 mm x 8 mm) and Large 1 1/2" x 3/16" (38 mm x 8 mm) aluminum rectangular hem bar with plastic endcaps.

LARGE FLAT EXPOSED HEM BAR: 1 1/2" x 3/16" (38 mm x 8 mm) aluminum rectangular hem bar with plastic endcaps.

ROUND EXPOSED HEM BAR: Small 5/8" (16 mm) and Large 13/16" (21 mm) aluminum with plastic endcaps.

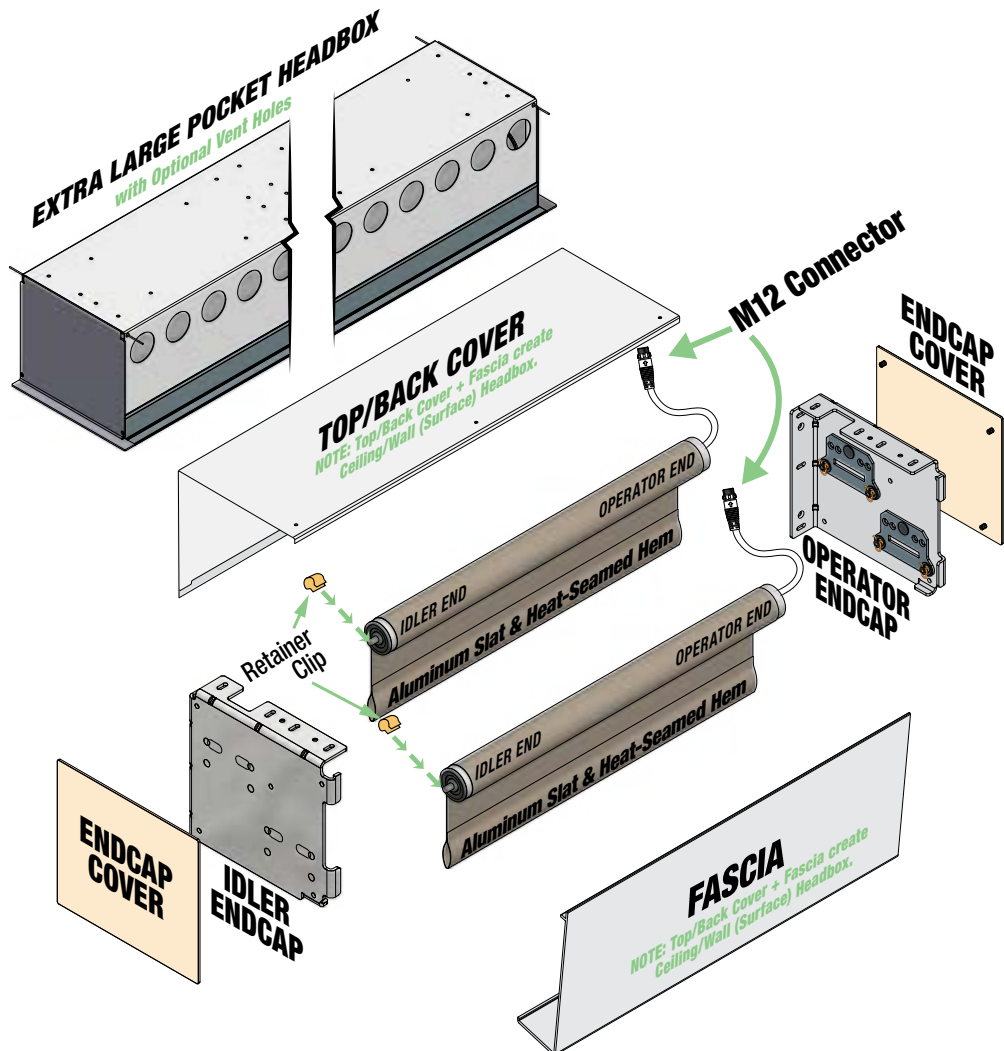

Extra Large Hardware Dimensions

Extra Large Dual Roller with Fascia Endcaps Only

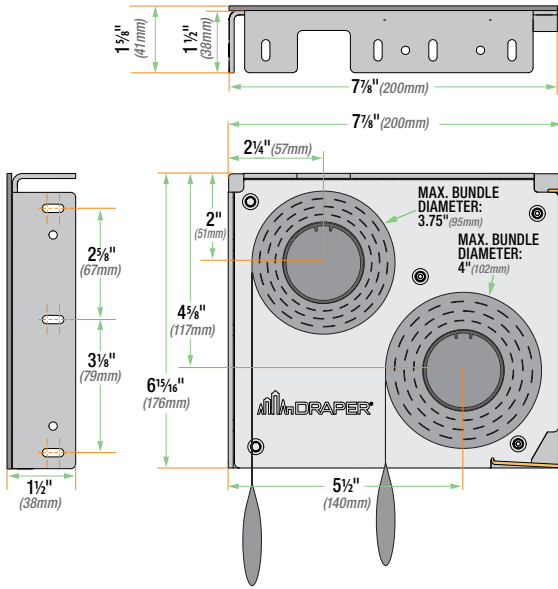

Extra Large Dual Roller with Surface Mount Headbox

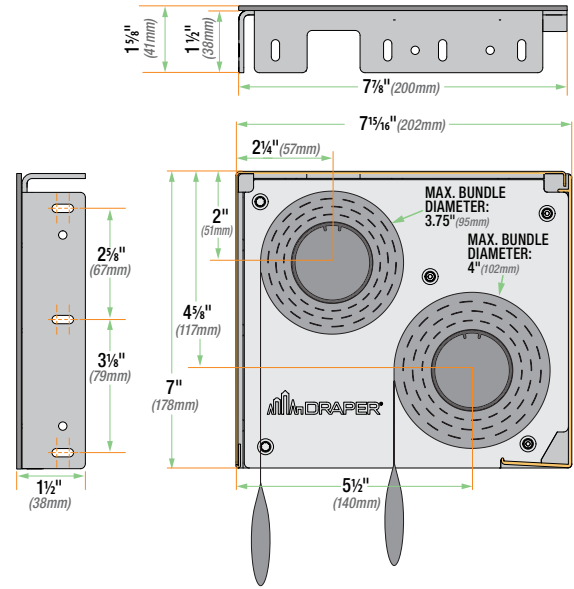

ROLLER TUBE CUT LENGTH - 1/8" (3.2mm) = FABRIC CUT WIDTH
 SHADE WIDTH (Outside Measurement) - 1 1/2" (38mm) = ROLLER TUBE CUT LENGTH
 FABRIC CUT WIDTH - 2" (51mm) = HEM BAR CUT LENGTH

*When measuring shade height, remember to include Endcaps & Fascia.

Extra Large Dual Roller with Pocket Headbox Dimensions

